

 **PIONEER**<sup>®</sup>  
The future of sound and vision.

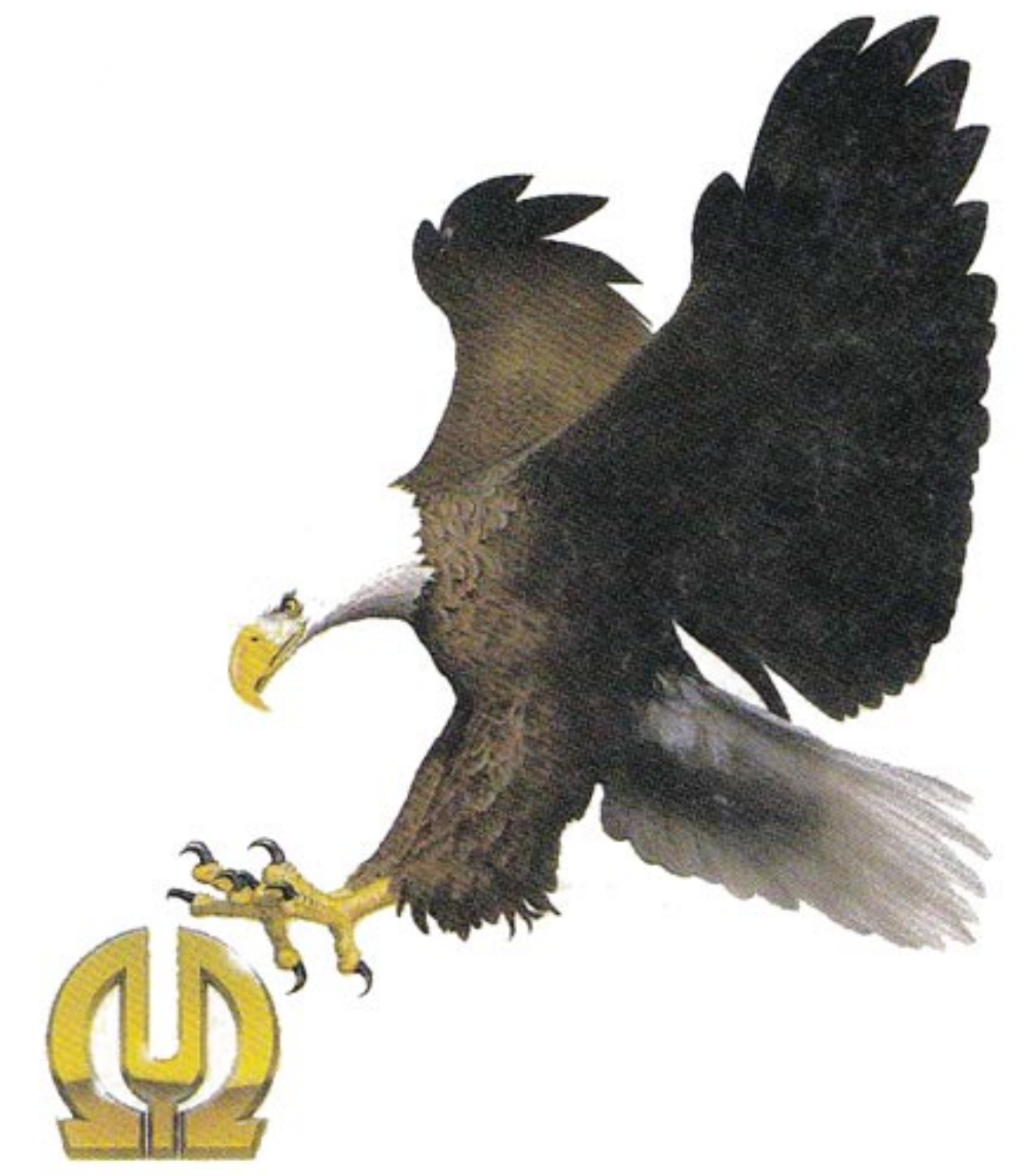

## Audio & Video Components & Systems

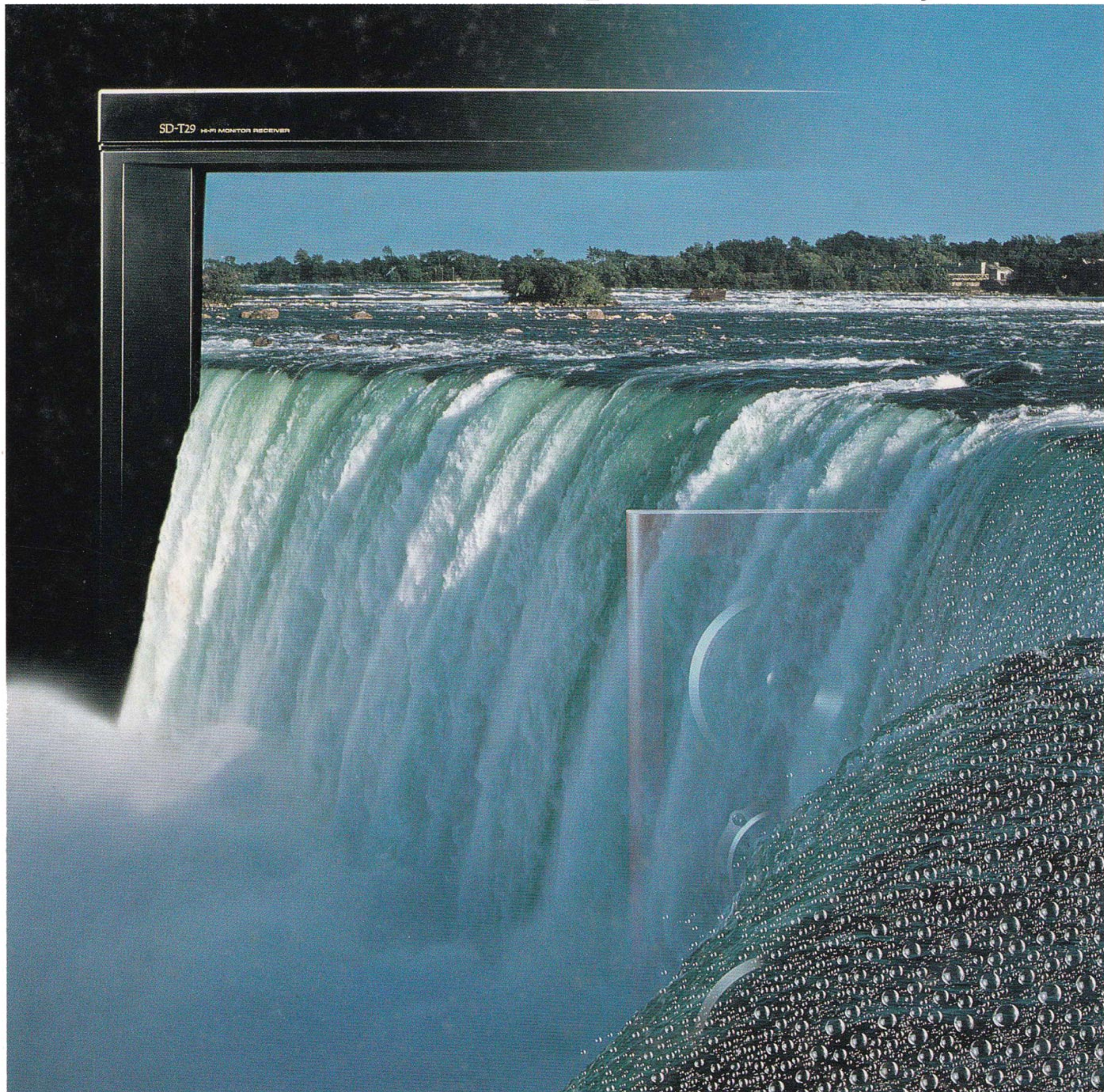

50 YEARS of FIDELITY

*Catch the Spirit of a True Pioneer*

Pioneer Presents

Total Home Entertainment.



# PIONEER AV COMPONENTS 1988 - 1989

## HI-FI COMPONENTS

### Compact Disc Players 6

PD-M900  
PD-M600  
PD-M500  
PD-7100  
PD-5100  
JD-M100/JD-M108

### AV Receivers 10

VSX-7300S  
VSX-5300  
VSX-3300  
JA-RF5

### Amplifiers 13

C-90S  
M-90  
A-717  
A-616  
VSA-910

### Tuners 17

F-91  
F-443

### Cassette Decks 18

CT-W900R  
CT-W770R  
CT-W500  
CT-2080R

### Turntable 19

PL-L70

### Speaker Systems 20

S-55TS  
CS-T7000  
CS-T6000  
CS-907  
CS-607  
S-X7

### SYSTEM STEREOS 23

SYSTEM CD900S  
SYSTEM CD700  
SYSTEM E2525  
SYSTEM CD360  
Z-70M

### VIDEO COMPONENTS

#### LD Players 28

CLD-3030  
CLD-1030  
LD-850D

#### Monitor/Receivers 31

SD-P4002  
SD-281  
SD-T29  
CB-X26

#### ADD-ONS/ ACCESSORIES 33

GR-777	GR-555
VSP-555	DT-555
EX-9000(BK)	SR-60(BK)
CU-AV100	B-W90
SE-M70	SE-30D(BK)
SE-450	SE-205

#### SPECIFICATIONS 35

**CATALOG** "Exchange Catalog" Item

**AAFES** AAFES Stock Assortment Item

**AAFES-EUROPE** AAFES-EUROPE Stock Assortment Item

**AAFES-PACIFIC** AAFES-PACIFIC Stock Assortment Item



# AN ORIGINAL PIONEER

*Putting Pure Technology to Work*

## A PIONEER ORIGINAL: Anti-Resonance Technologies

Sound is a series of vibrations. Until it is reproduced as soundwaves, it's in the form of rather weak electrical signals which, if exposed to unwanted vibrations or interference inside your amp, tuner or other component, can be easily damaged. Pioneer's long experience in hi-fi (we celebrate our 50th year in 1988) has led to our "Anti-Resonance" design policy.

This policy is implemented in a number of ways. For example, the latest Pioneer CD players, amplifiers, tuners, cassette decks and LD players introduced in this catalog make use of a "honeycomb" design in the materials used in strategic points — such as the chassis, separators, heat sinks, insulators, etc. It increases rigidity and discourages internal and external vibration. Also, in our CD and LD players, various Disc Stabilizer designs are developed to prevent unwanted vibrations from being propagated to other sensitive parts such as pickups or other circuits.

Not surprisingly, related methods of assuring pure sound quality also abound in the latest Pioneer hi-fi products shown in this brochure. Of particular note are the "Direct Circuit Connection" ("Short Path") and "Separate Circuit" designs and "Monophonic-times-Two" configurations, explained in detail in later pages.

## Pioneer SR System

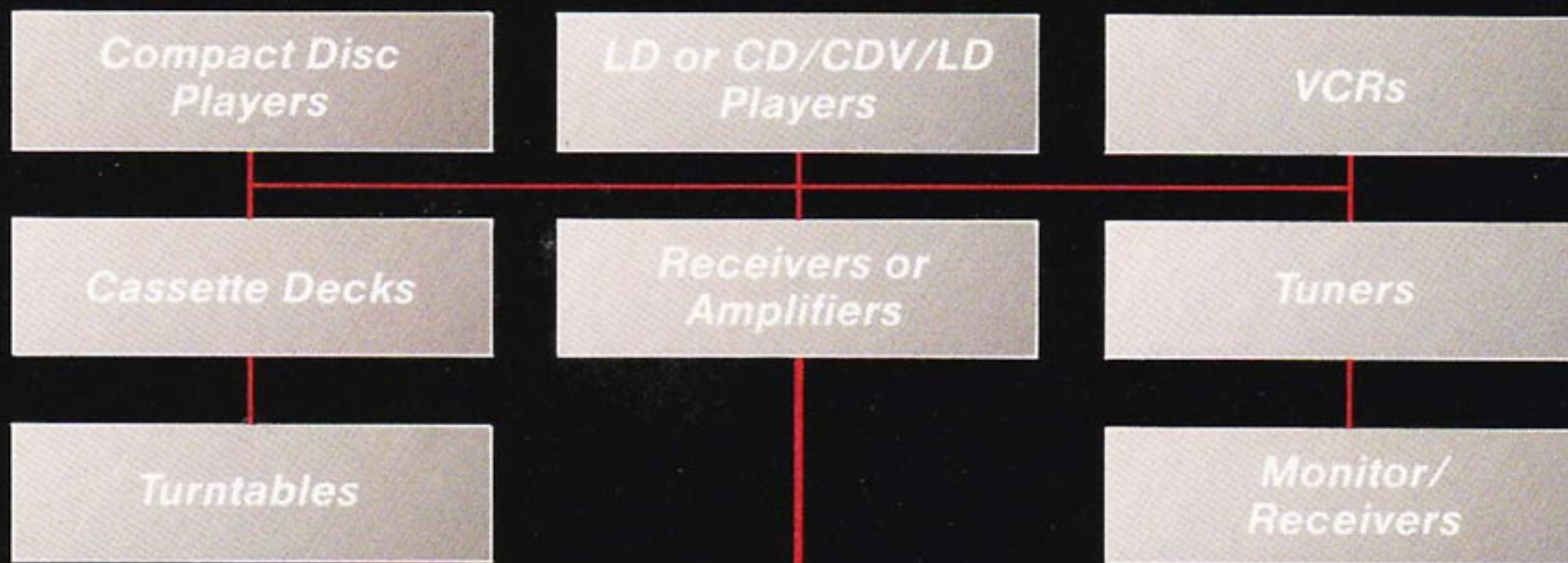

## A PIONEER ORIGINAL: "6-Pack CD Multiplay"

Pioneer invented 6-disc CD "Multiplay." That's right! Ours was the world's very first player to use the handy "6-Pack," you can enjoy up to seven hours, twelve minutes of uninterrupted playback.

This technology and convenience is now extended to our latest CD multiplay for cars. Enjoy Pioneer multiplay CD at home and on the road.

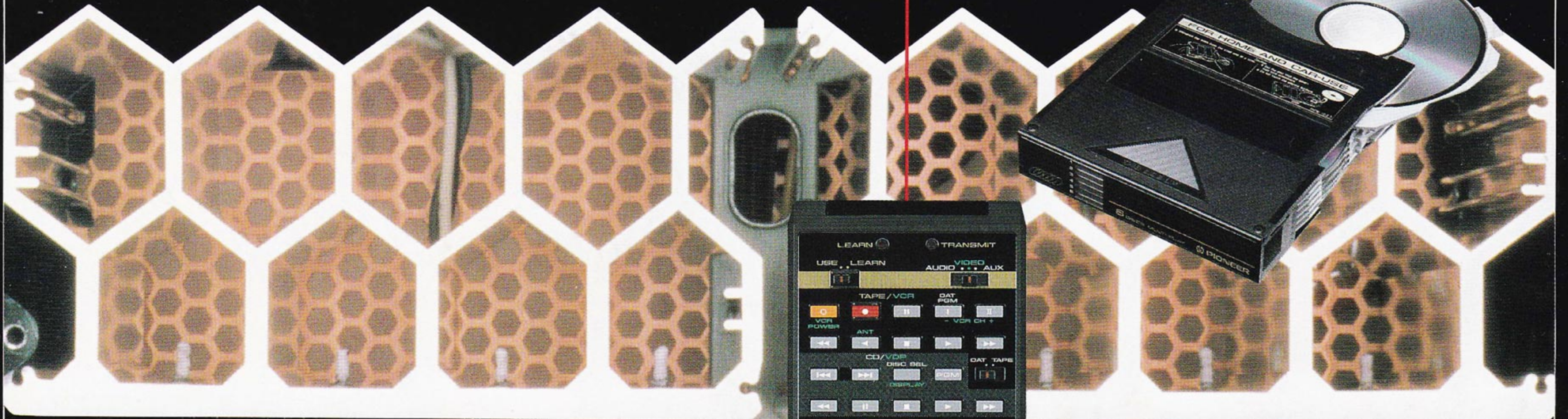

## A PIONEER ORIGINAL: AV "Smart Remote"

Our "Smart Remote"™ Control Unit is really "smart." And not just in looks. It features powerful control of the operation of our AV Amplifier VSA-910, AV Receiver VSX-7300S, Control Amplifier C-90S and SYSTEM CD900S. Because it is an SR (System Remote) type, it also gives you fingertip command of the major functions of other Pioneer SR components. But the real advantage is its "learning" capability — letting you control other, non-Pioneer components from it, as well.

It's easy to "teach" this controller the infrared codes for remote control of other audio and video home-entertainment components — even those that don't carry the Pioneer name.

The AV keys control virtually all the PLAY, REC, PAUSE, F-FWD/REW, track/ band/ channel/station and other capabilities of CD and analog record players, DAT and analog cassette decks, tuners and AUX units, LD players, VCRs and even TVs.

As we said, this "smart" unit is included in the price of several of the Pioneer components shown in this catalog. But it's also available separately — at what we think is a VERY reasonable price! For details on the unit (called the CU-AV100), please see page 34.

CU-AV100

Programmable "Smart Remote"™



# HI-FI COMPONENTS

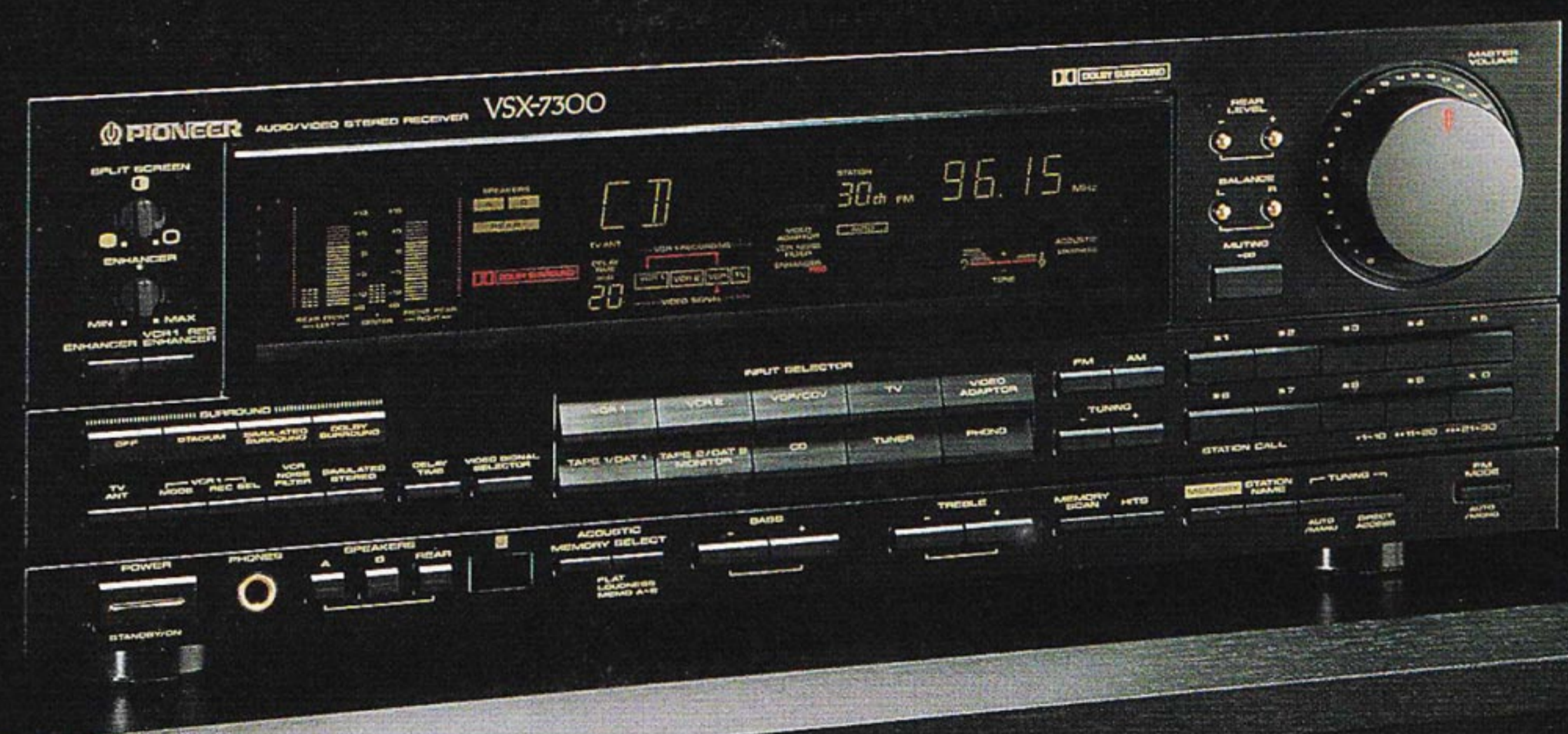

## Faithful to the Original

The "fi" of "hi-fi" is supposed to mean "faithful." At Pioneer it does, thanks to our long experience and continuing investment in original audio, digital and laser technologies. You can believe it when you hear it, and to hear it, just audition any or all the audio products in this catalog before you make your buying decision. You won't be disappointed.

# Compact Disc Players

## Pioneer Technology at Work in CD

COMPACT  
disc  
DIGITAL AUDIO

### Oversampling Digital Filters

The standard sampling frequency of the CD format is 44.1kHz. This is the number of times per second the original sound is "read" by the Analog-to-Digital (A/D) converter for translation into the digitized data that goes on the CD. The 44.1kHz frequency is more than adequate in covering the audible frequency spectrum (e.g., 0Hz to 20kHz), but it does cause some problems at the Digital-to-Analog (D/A) conversion stage — which happens inside the CD player: it can result in the generation of "sampling" noise because its "foldover" frequencies are spectrally close to the audible frequency range.

#### Spectra of Sampling Noise

(1) Without Oversampling

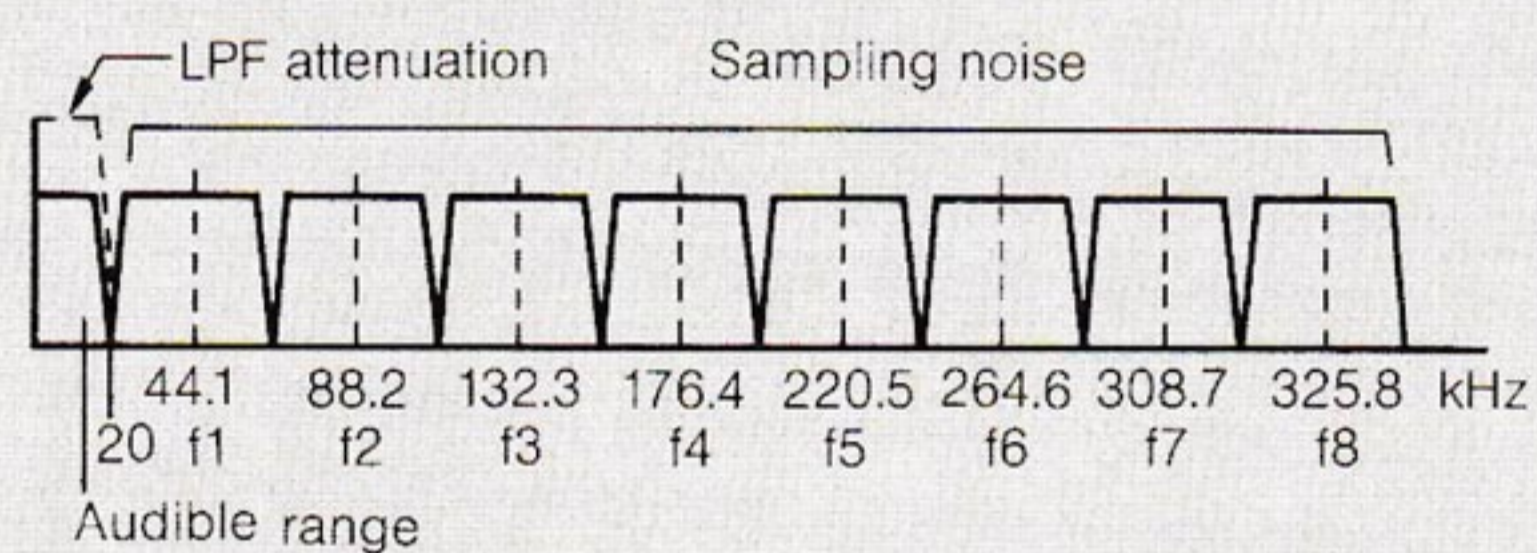

(2) With 8-Times Oversampling

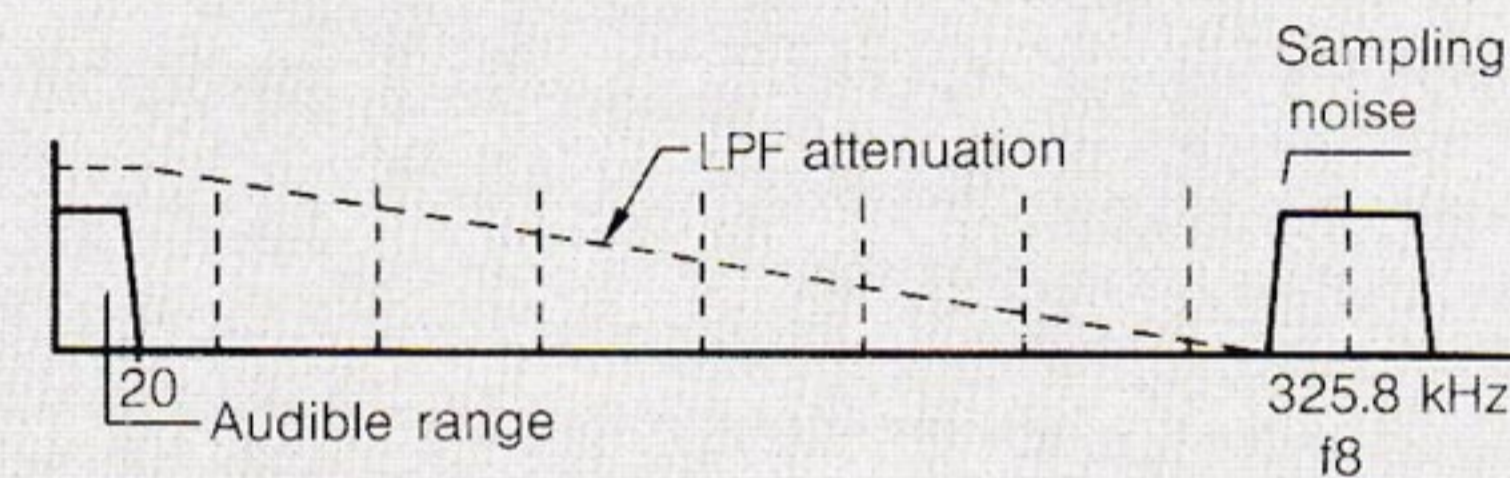

### Quantization Noise Generation (Conceptual)

(1) Without Oversampling

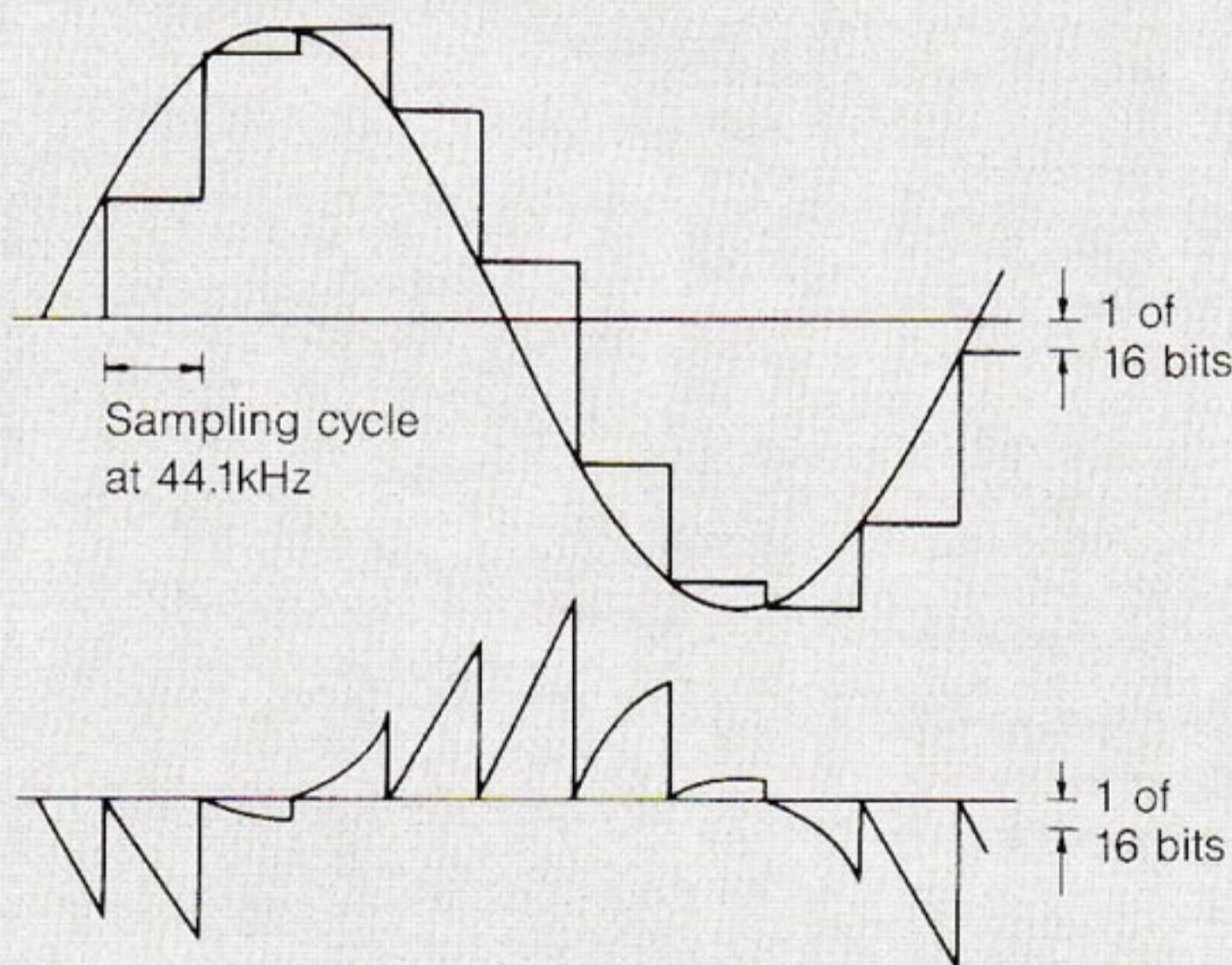

(2) With 16-Bit 8-Times Oversampling

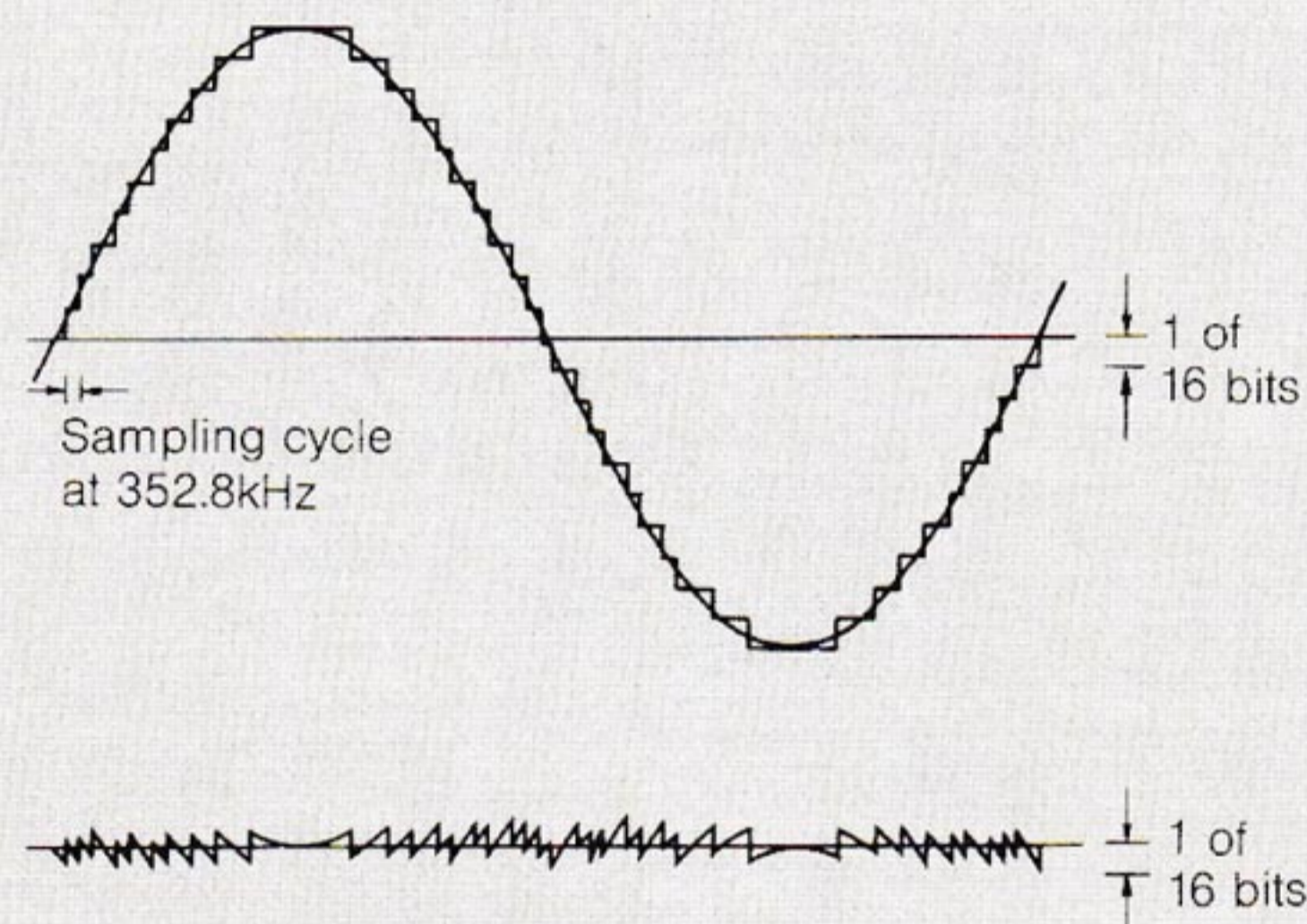

### Twin D/A Converters

Two separate D/A converters, one per channel, are incorporated in all of our new CD players. They reduce phase differences between channels virtually to zero. In addition, the converters use a "laser-trim" method to cancel "glitch" noise that occurs in digital-to-analog conversion.

### "Linear-Envelope" Design

The latest technology adds 16-bit linear-envelope performance for D/A conversion in the PD-M900/M600 and PD-7100; these models have 16-bit quantization capability and well-controlled current flow, so that when digital signals are converted to analog, the results more closely parallel those of the original sound source.

### Class-A FET Buffer Amp

Class-A FET Buffer Amp is employed at the last step in the OP amp configuration of the PD-M900 and PD-7100. It reduces loads and impedance in the OP amp, securing an audio part from power-supply load variations. Its "Class-A" amplifier design assures high-quality performance with low distortion and noise.

The accepted way of avoiding the problem is to geometrically boost the original frequency by a factor of 2X — or more — with the use of what are called "Oversampling Filters."

All our new Compact Disc players are provided with high-grade oversampling digital filters — either 4X or 8X types. Both versions shift the "foldover" frequencies far beyond the audible range (to 176.4kHz with 4X filters, to 352.8kHz with 8X filters) to suppress generation of quantization noise to a minimum (see chart).

### Low Center-of-Gravity Ballast Base

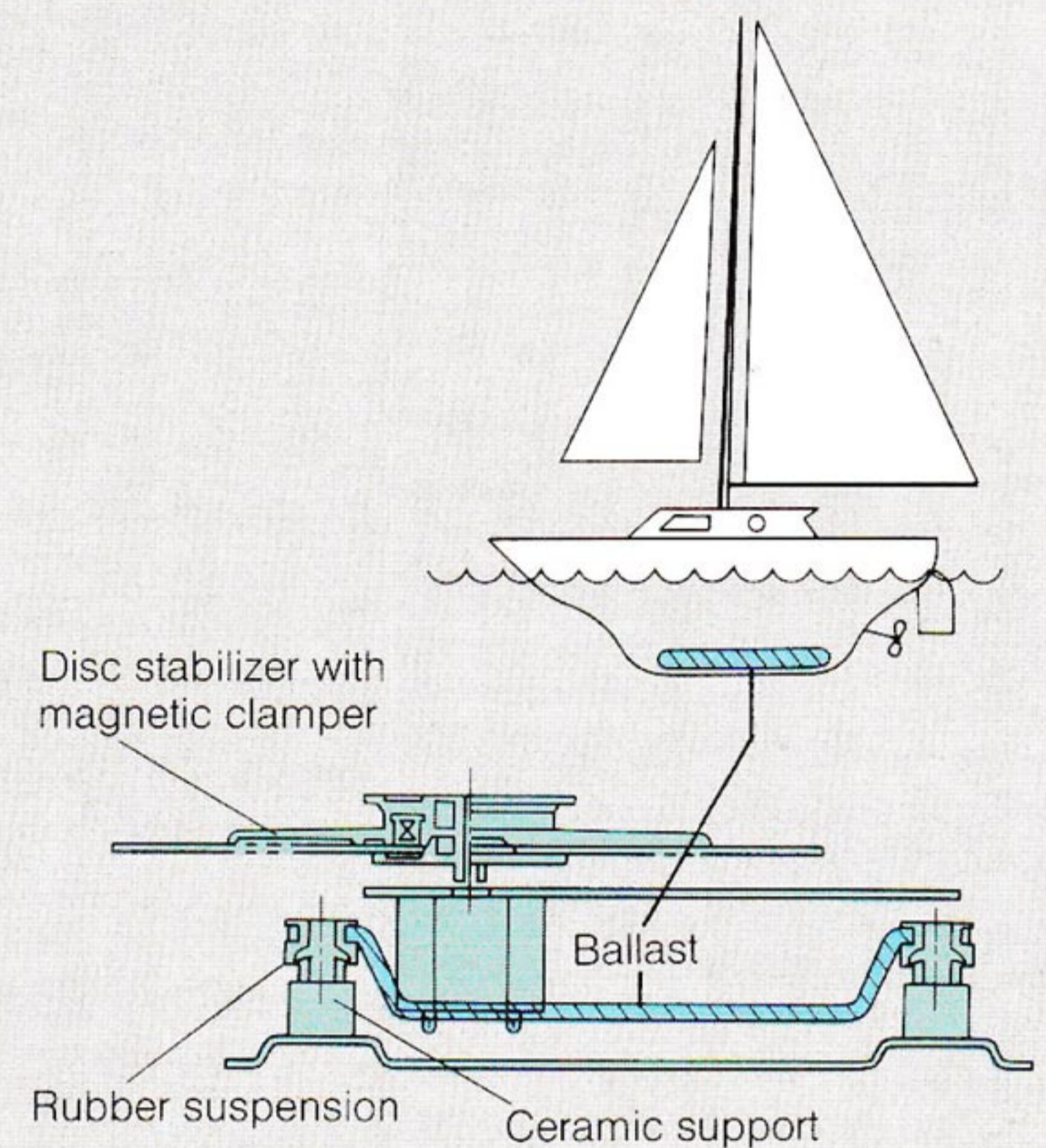

### Multiplay CD Convenience

Here are some of the benefits of CD multiplay:

- 32-track programming from all six discs
- Track, Disc and Magazine Repeat
- Random Play in which a microprocessor selects the playlist from all discs, or from only those programmed.

Brand-new conveniences include:

- Disc-Level Memory to control level "volume" disc by disc
- Status Memory Backup to return to the last-used mode upon power-on
- "Delete" Random Play to skip tracks you don't want to hear.



JD-M100  
6-Disc Magazine

### Accu-Focus System

The photodetector in the laser pickup is divided into four components to control the focus servo. To prevent phase differences in the four separate signals received in the detector, a delay circuit is added to the first-arriving signals (see chart); this greatly reduces distortion and improves frequency response in the RF output.

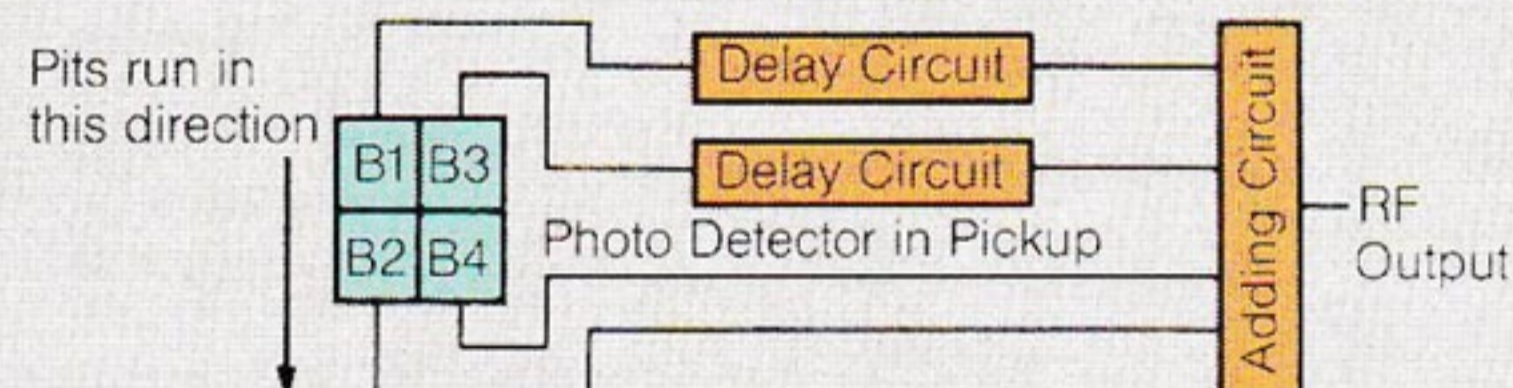

B1, B4 receive signals before B2, B3 do. B1, B4 signals are sent to their own delay circuits, and applied to the adding circuit. There all four signals are synchronized and then output as RF signals, resulting in a high signal-to-noise ratio and low distortion.

### Anti-Resonance Design

Our "Anti-Resonance" design is materialized in a form of "Honeycomb" baseplate. Our Multi-Play models are provided with "honeycombed" Large Insulators and Disc Stabilizers, and PD-7100 and PD-5100 have Magnet Clamping Disc Stabilizers and "Ballast-Base" Design. Wherever we can, we are developing this design concept — to cancel all the unwanted resonance for reproduction of closer-to-the-original sound.

### More Good Ideas

- **Digital Level Control:** Microchips attenuate output volume digitally for smooth operation; convenient to adjust levels of discs in CD multiplay.
- **Auto Program Editing:** Helps you dub CDs (where law permits) by telling you the running time of programmed selections so you can easily know how many will fit on the cassette tape you use.
- **One-Touch Digital Fade:** A specially designed IC protects sound quality while letting you fade music in and out at any time.
- **Time Fade Editing:** Similar to the above, this feature automatically fades out a tune during dubbing at the time-point you specify.
- **Variable Fade:** Enables you to choose duration of in or out fading from 0 to 9 seconds.
- **"Music Window":** Lets you choose portions of music anywhere in a disc to play them consecutively with fade-ins and -outs; program up to eight music portions.
- **Auto Space:** Create breaks between songs for easy tape editing.

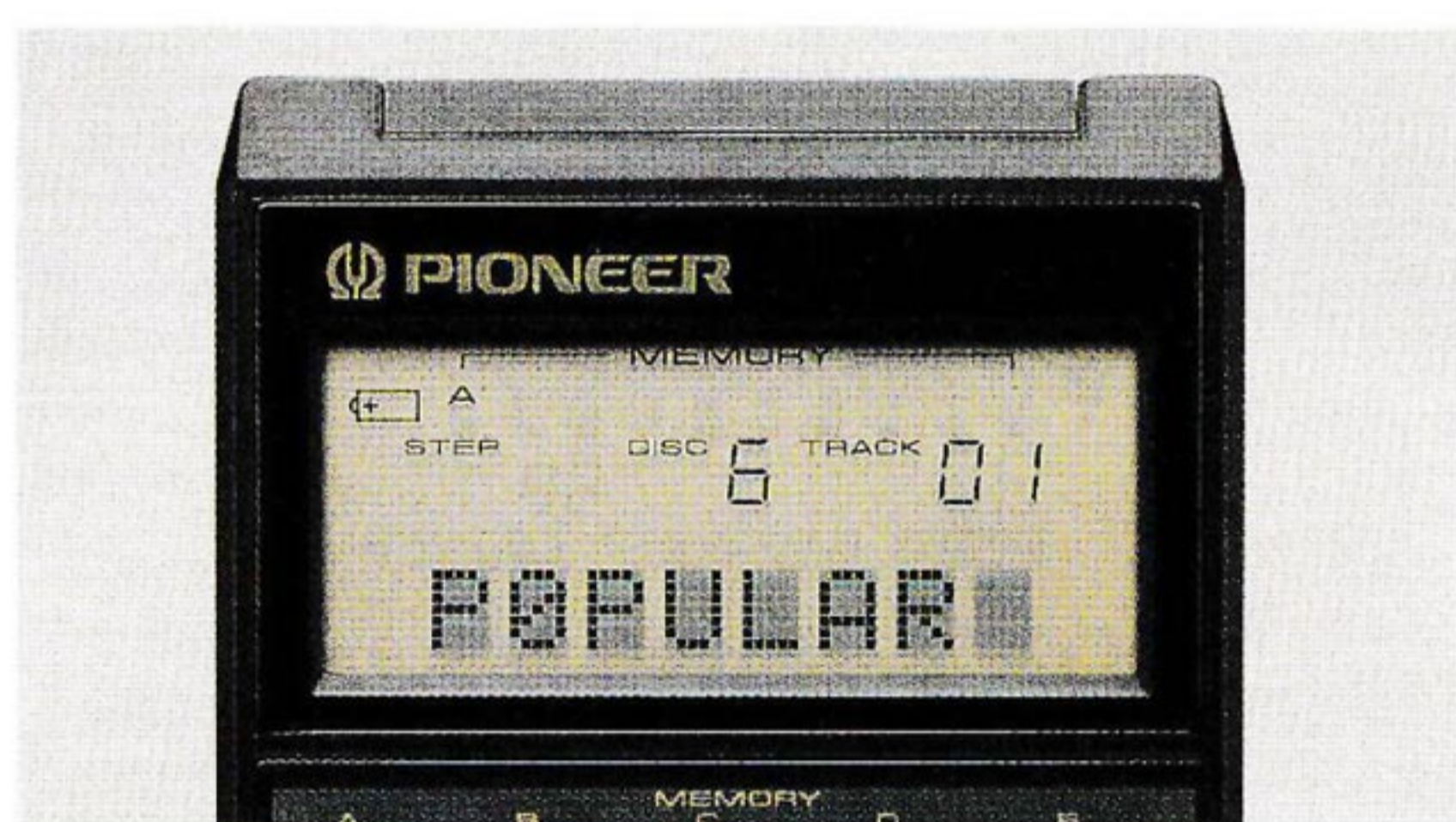
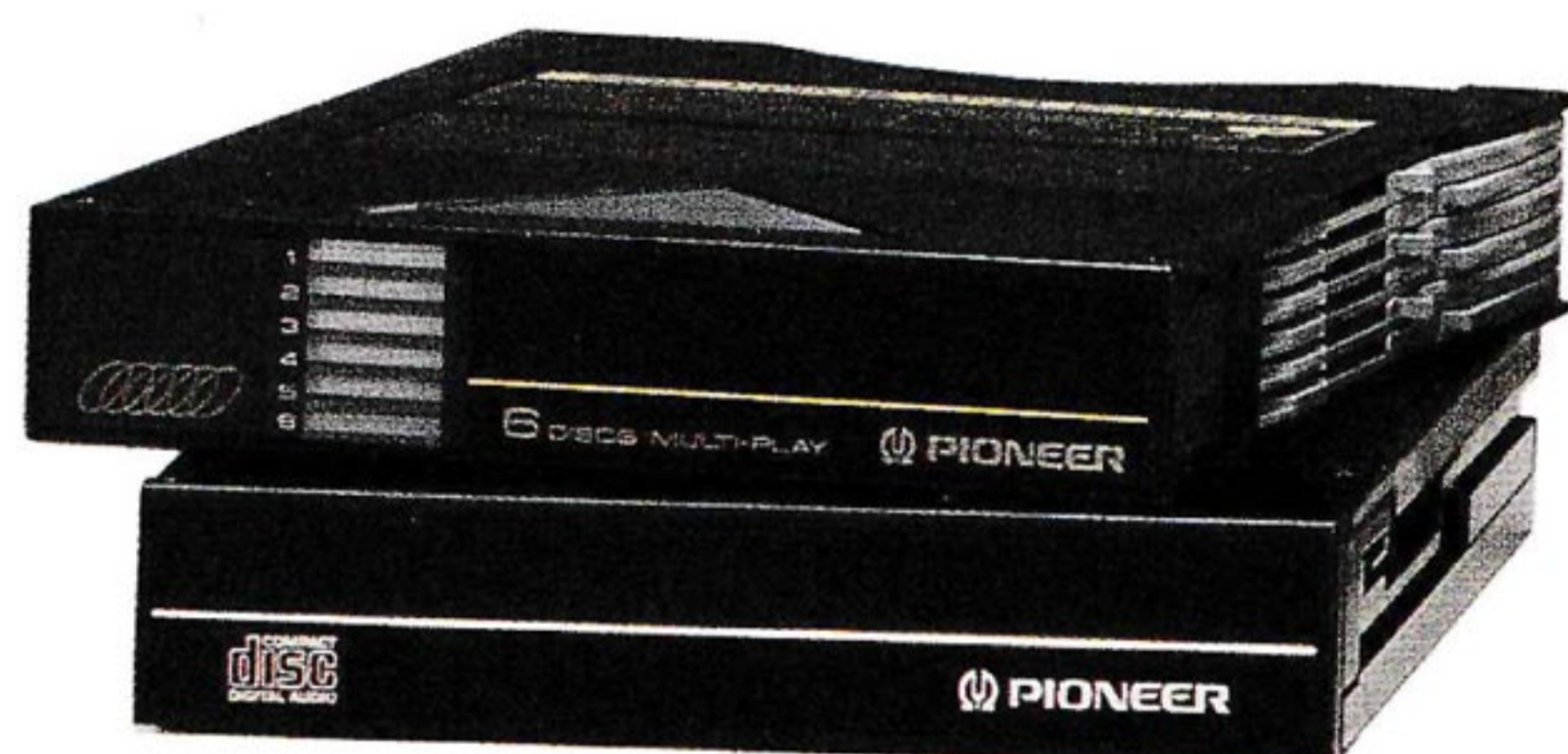

Multi-Information LC Display on Remote Control for PD-M900

### CD Multiplay Remote Control

All Pioneer CD multiplayers have a multifunctional Remote Controller, which (except on the PD-M500) has a liquid-crystal display to make programming and play easier. The controller for the PD-M900 and PD-M600 includes MPSS\* (Magazine Program Selection System) that accepts 256 entries (selections and pauses) for ten "6-Packs." MPSS programming can be done even in a different room; when you are within range of the player, push a button to transfer the program to memory. The PD-M900's remote has a convenient function to let a user write in programmed magazine labels and show them on the display. (See photo.)

#### Notes:

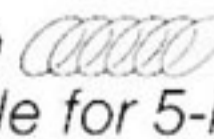
- (1) The PD-M900, PD-M600 and PD-M500 come with one six-disc magazine (JD-M100) and a single-disc loader.
- (2) The magazine-type Multi-Play CD players with  mark and the magazines with the same mark are compatible for 5-inch (12cm) discs.

AAFES CATALOG  
CRC No. 9292608

## PD-M900

### Multi-Play Compact Disc Player

- **8-Times Oversampling Digital Filter:** Low distortion and more accurate phase linearity is achieved with the use of a low-order analog filter and the technique of boosting the sampling frequency to 352.8kHz to shift noise into the inaudible range.
- **Twin Linear-Envelope 16-Bit D/A Converters:** Two separate, "glitchless" D/A converters, one per channel reduce phase differences between channels. The sound you hear is closer to the original thanks to a new 16-bit "linear-envelope" design.
- **Accu-Focus System:** Reduces distortion and improves frequency response in the RF output.
- **Class-A FET Buffer Amp:** Distortion is lowered over the entire frequency spectrum for clearer sound reproduction.
- **Separate Power Supply:** Power is supplied separately to analog, servo and digital circuits to cancel mutual interference.
- **Anti-Resonance Design Policy:** Copper-plated Honeycomb Chassis and Large Insulators defeat external vibrations.
- **Full-Function Remote Control:** Numeric keypad and liquid-crystal display increase versatility. New "write-in" function lets you show programmed magazine labels in eight alphabetic characters on the dot-matrix display. MPSS (Magazine Program Selection System) is also provided.
- **Programmed Play:** Enter your choice of up to 32 tracks from any or all six discs for automatic playback in the order you want.
- **Random Play:** Microprocessor selects track/disc playlist at random, avoiding repeats; Random Play also available for only those selections (up to 32) you have programmed; "Delete" Random Play also provided.
- **Editing Conveniences:** Mastering the art of music editing is a cinch with Disc-Level Memory, One-Touch Fade, Time-Fade Edit, Auto-Fade and Programmable Pause.
- Direct Program, 2-Speed Manual Search and 3-Way Repeat
- Digital Level Control and Level Memory
- Coaxial-Cable and Optical Digital Outputs
- Subcode Output
- Headphone Output with Volume Control
- Timer Play (with optional timer) and Battery Backup for Status Memory
- Comes with a 6-Disc Magazine and Single-Disc Loader

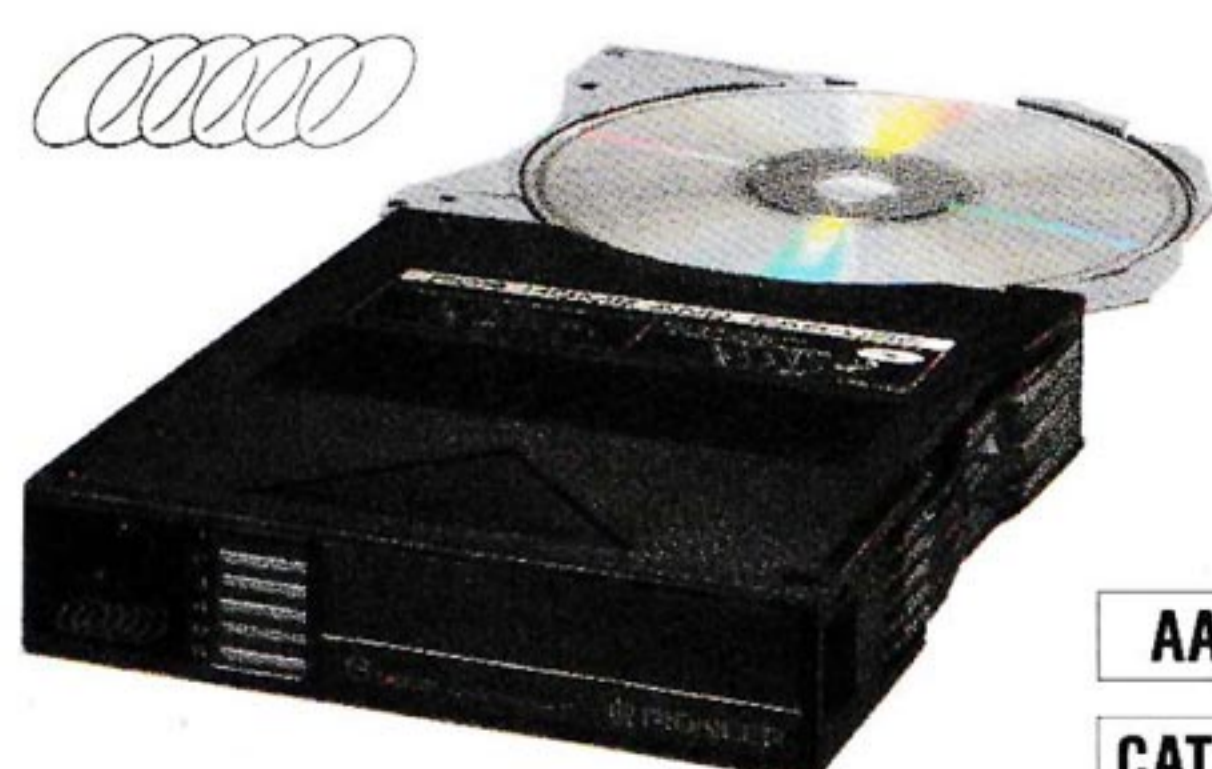

AAFES  
CATALOG

CRC No. 9078502

## JD-M100

### 6-Disc Magazine

Call it a "6-Pack" if you like — it's as just as handy, and even more fun. One six-disc magazine is provided with all three Multi-Play CD Players shown here, and spares are available at option. Build your own home CD library — jazz in one, classical in another, rock or CW or anything else in still others. This convenience is extended to our latest CD multi-player (CDX-M100) for cars — using the same JD-M100 six-disc magazine for convenient compatibility. Pop in a "6-Pack," and enjoy the same multiplay CD performance at home and on the road.

## JD-M108

### 3-Inch CD Magazine

"6-Pack" convenience is extended to 3-inch CDs with multiplay magazine.

## PD-M600

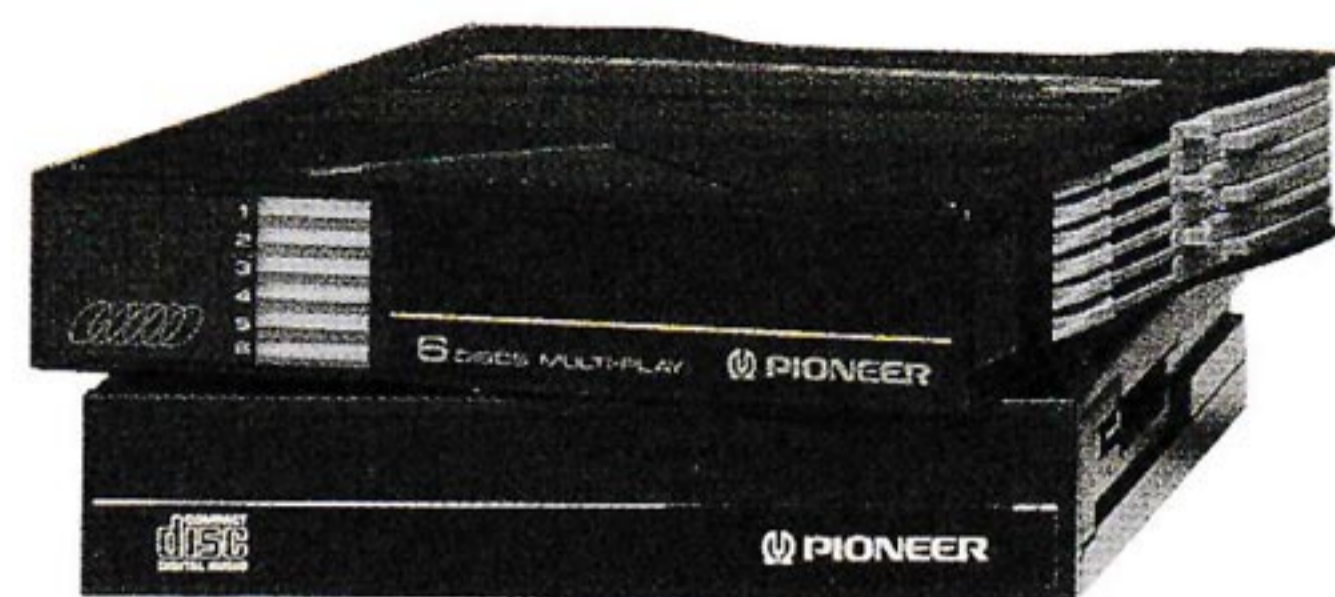

AAFES CATALOG  
CRC No. 9292004

## PD-M500

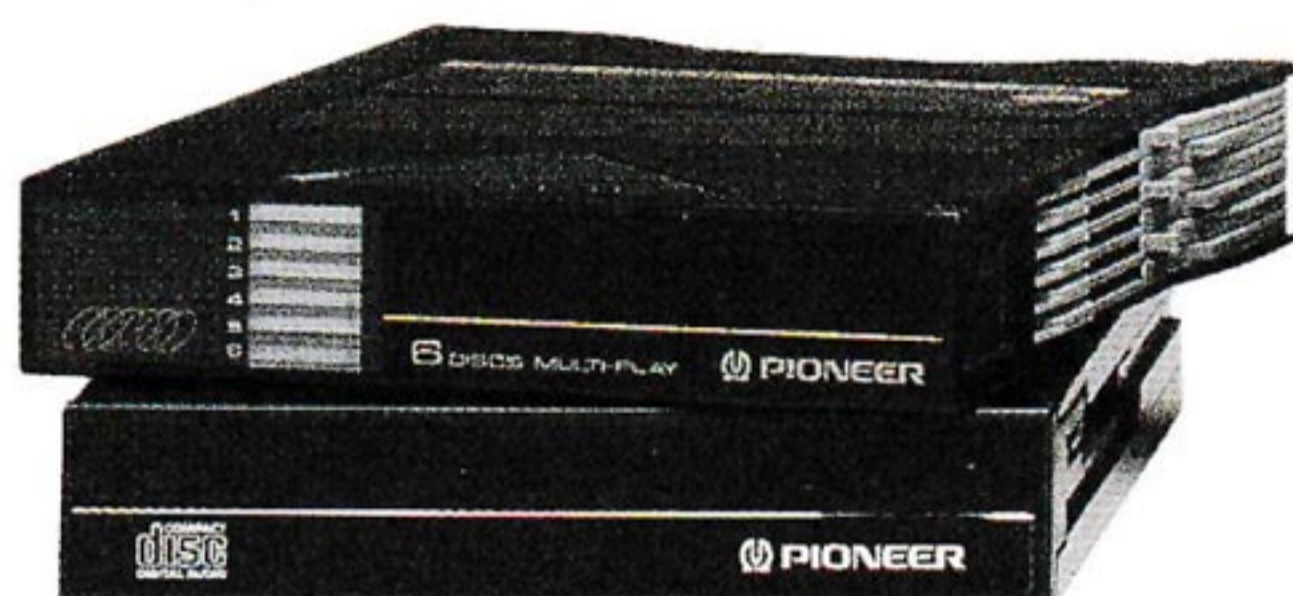

AAFES CATALOG  
CRC No. 9292111

## PD-M600

### Multi-Play Compact Disc Player

- **4-Times Oversampling Digital Filter:** Lower distortion and more accurate phase linearity is achieved with the use of a low-order analog filter and the technique of boosting the sampling frequency to 176.4kHz to shift noise into the inaudible range.
- **Twin Linear-Envelope 16-Bit D/A Converters:** Two separate, "glitchless" D/A converters, one per channel reduce phase differences between channels. The sound you hear is closer to the original thanks to a new 16-bit "linear-envelope" design.
- **Accu-Focus System:** Reduces distortion and improves frequency response in the RF output.
- **Anti-Resonance Design Policy:** Honeycomb Chassis, Ribbed Bonnet and Large Insulators defeat external vibrations.
- **Full-Function Remote Control:** Numeric keypad and liquid-crystal display increase versatility. MPSS (Magazine Program Selection System) is also provided.
- **Programmed Play:** Enter your choice of up to 32 tracks from any or all six discs for automatic playback in the order you want.
- **Random Play:** Microprocessor selects track/disc playlist at random, avoiding repeats; Random Play also available for only those selections (up to 32) you have programmed; "Delete" Random Play also provided.
- **Editing Conveniences:** Mastering the art of music editing is a cinch with Disc-Level Memory, One-Touch Fade, Time-Fade Edit, Auto-Fade, and Programmable Pause.
- Direct Program, 2-Speed Manual Search and 3-Way Repeat
- Digital Level Control and Level Memory
- Subcode Output
- Headphone Output with Volume Control
- Timer Play (with optional timer)
- Comes with a 6-Disc Magazine and Single-Disc Loader

## PD-M500

### Multi-Play Compact Disc Player

- **4-Times Oversampling Digital Filter:** Lower distortion and more accurate phase linearity is achieved with the use of a low-order analog filter and the technique of boosting the sampling frequency to 176.4kHz to shift noise into the inaudible range.
- **Twin 16-Bit D/A Converters:** Two separate, "glitchless" D/A converters, one per channel reduce phase differences between channels virtually to zero.
- **Accu-Focus System:** Reduces distortion and improves frequency response in the RF output.
- **Anti-Resonance Design Policy:** Honeycomb Chassis, Ribbed Bonnet and Large Insulators defeat external vibrations; Disc Stabilizer improves tracking by reducing vibrations.
- **Full-Function Remote Control:** Numeric keypad and other multi-functional keys are provided.
- **Programmed Play:** Enter your choice of up to 32 tracks from any or all six discs for automatic playback in the order you want.
- **Random Play:** Microprocessor decides track/disc playlist at random, avoiding repetitions.
- **Editing Conveniences:** Mastering the art of music editing is a cinch with Time-Fade Edit, and Programmable Pause.
- Direct Program, 2-Speed Manual Search and 3-Way Repeat
- Digital Level Control
- Headphone Output with Volume Control
- Timer Play (with optional timer)
- Comes with a 6-Disc Magazine and Single-Disc Loader





AAFES CATALOG  
CRC No. 9288929

## PD-7100

### Compact Disc Player

- **8-Times Oversampling Digital Filter:** Lower distortion and more accurate phase linearity is achieved with the use of a low-order analog filter and the technique of boosting the sampling frequency to 352.8kHz to shift noise into the inaudible range.
- **Twin Linear-Envelope 16-Bit D/A Converters:** Two separate, "glitchless" D/A converters, one per channel reduce phase differences between channels. The sound you hear is closer to the original thanks to a new 16-bit "linear-envelope" design.
- **Accu-Focus System:** Reduces distortion and improves frequency response in the RF output.
- **Class-A FET Buffer Amp:** Distortion is lowered over the entire frequency spectrum for clearer sound reproduction.
- **Separate Power Supply:** For stable, low-distortion performance.
- **Anti-Resonance Design Policy:** "Ballast Base" design, Honeycomb Chassis and Large Insulators defeat external vibrations; Magnetic Clamping Disc Stabilizer reduces propagation of unwanted vibrations.
- **3-Inch CD Single:** Play 3-inch CDs without an adaptor.
- **Full-Function Remote Control:** Numeric keypad and other multi-functional keys.
- **Programmed Play:** Enter your choice of up to 24 tracks; your choice is shown on the "Contents Calendar."
- **Random Play:** Microprocessor decides track/disc playlist at random, avoiding repetitions.
- **Editing Conveniences:** Mastering the art of music editing is a cinch with Auto-Program Edit, One-Touch Fade, Time-Fade Edit, Variable-Fade and Programmable Pause.
- "Music Window" and Direct-Access Track Play
- 2-Speed Manual Search and 3-Way Repeat
- Digital Level Control & Coaxial-Cable and Optical Digital Outputs
- Headphone Output with Volume Control and Timer Play (with optional timer)

## PD-5100

### Compact Disc Player

- **4-Times Oversampling Digital Filter:** Lower distortion and more accurate phase linearity is achieved with the use of a low-order analog filter and the technique of boosting the sampling frequency to 176.4kHz to shift noise into the inaudible range.
- **Twin 16-Bit D/A Converters:** Two separate, "glitchless" D/A converters, one per channel reduce phase differences between channels virtually to zero.
- **Anti-Resonance Design Policy:** "Ballast Base" design, Honeycomb Chassis and Large Insulators defeat external vibrations; Magnetic Clamping Disc Stabilizer reduces propagation of unwanted vibrations.
- **3-Inch CD Single:** Play 3-inch CDs without an adaptor.
- **Full-Function Remote Control:** Numeric keypad and other multi-functional keys.
- **Programmed Play:** Enter your choice of up to 20 tracks; your choice is shown on the "Contents Calendar."
- **Random Play:** Microprocessor decides track/disc playlist at random, avoiding repetitions.
- **Editing Conveniences:** Mastering the art of music editing is a cinch with Auto-Program Edit and Programmable Pause.
- Direct-Access Track Play, 2-Speed Manual Search and 3-Way Repeat
- Headphone Output with Volume Control and Timer Play (with optional timer)

### Feature Comparison

	PD-M900	PD-M600	PD-M500	PD-7100	PD-5100
Digital Filter	8X	4X	4X	8X	4X
Twin D/A Converters	○	○	○	○	○
"Linear-Envelope" D/A Converter	○	○	○	○	○
Class-A FET Buffer Amp	○	○	○	○	○
Accu-Focus System	○	○	○	○	○
Disc Stabilizer	○	○	○	Magnet	Magnet
3-Inch CD-Single Play (without adaptor) (with 3-inch CD magazine)	○	○	○	○	○
Random Play	○	○	○	○	○
Delete Random Play	○	○	○	○	○
Programmable Tracks	32	32	32	24	20
Digital Level Control	○	○	○	○	○
Level Memory	○	○	○	○	○
One-Touch Fade	○	○	○	○	○
Variable Fade	○	○	○	○	○
MPSS	○	○	○	○	○
"Music Window"	○	○	○	○	○
Auto-Program Edit	○	○	○	○	○
Time-Fade Edit	○	○	○	○	○
Search & Repeat	○	○	○	○	○
Timer Play (with optional timer)	○	○	○	○	○
Digital Output	○	○	○	○	○
Subcode Output	○	○	○	○	○
Headphone Output with Volume	○	○	○	○	○
Full-Function Remote Control	○	○	○	○	○

# AV Receivers

## Pioneer Technology at Work in AV Receivers

### AV "Smart Remote"™

This "Smart Remote"™ is included in the price of many of our best products, including the VSX-7300S AV Receiver. The 68-key unit handles virtually every function of these components, the major operations of other Pioneer SR components and — a big bonus! — the major functions of many non-Pioneer components as well.

With its "learning" capability it's easy to "teach" the unit the infrared codes used in other remote controllers — those that come with amps, receivers, TVs and VCRs, even certain auxiliary components from virtually any manufacturer. Just place it head to head near the other remote and let it "learn" the desired codes one at a time.

### Digital Dolby Surround

Surround-sound processing delivers a true AV sensation. With the VSX-7300S and VSX-5300, a digital Dolby Surround creates the feeling that sound is coming from the sides, back and even above — much as in a movie theater or at a concert. All the surround-sound effects with these two models are digitally processed for low-distortion performance, and Digital Delay function allows you to control effects in 15, 20 and 30 milliseconds. Stadium and Simulated Surround features are also provided for extended use of surround effects. The VSX-7300S, provided with a center-channel output and control, can connect and place a subwoofer in the center between left/right speaker systems, and enables you to form a sound system with clear, localized sound images. The VSX-3300 is also provided with surround-sound effects using speaker matrix design. All receivers have Simulated Stereo for "stereo" effects from mono programs.

### Preset Tuning via Your Own Custom Codes

The added convenience of instant recall of 30 or 24 of your favorite FM and AM stations comes with the accuracy of Quartz-PLL digital synthesized tuning in all three of our AV receivers. You can even give certain stations your own "custom code" consisting of alphanumeric combinations up to five digits — such as CLAS1 or JAZZ2 or NEWS3, etc. These codes are then assigned to preset stations on the VSX-7300S (30 stations) and VSX-5300 (10 stations), and are shown on the large FL display panel every time you recall them.

With the VSX-7300S, Search operation is also made very sophisticated with HIT (Hyper Intelligent Tuning); just enter a single letter or number and touch the Search button to start the tuner searching for a certain group of frequencies or names. Also, searching up or down the band for stations in the order of signal strength is one-touch simple. Naturally, Preset Station Scan convenience is provided on all models.

### Multiple Video Copy Conveniences

"Total AV control" is more than a promise in our three AV receivers. Each has a Video Signal Selector, for example, letting you send your choice of video signals to the screen regardless of what audio you are hearing. As for inputs/outputs, the VSX-7300S handles VCR 1 & 2, LD player, video adaptor and TV, and has two TV outs. Use its REC enhancer to record from TV or dub from another VCR or LD player with sharper and cleaner pictures. Combined with the split-screen function, you can dub while you compare the enhanced and non-enhanced versions, side by side on the screen. Two-way dubbing between, and simultaneous output to two VCRs are additional conveniences. Input/Outputs on the VSX-5300 handles VCR 1 and 2 and an LD player, and split-screen comparison and two-way dubbing are also provided.

### Large Multi-Information FL Display

All three Pioneer AV Receivers have a large multi-information FL display showing all necessary operation status data: FM/AM tuning frequencies, left/right volume level, scan or search play, etc. The alphanumeric display shows you the name of selected source. An extra convenience is found in the VSX-7300S and VSX-5300 — the ability to "write in" the names or call letters of preset FM/AM stations (up to five characters); you can even change names of function switches if you wish.

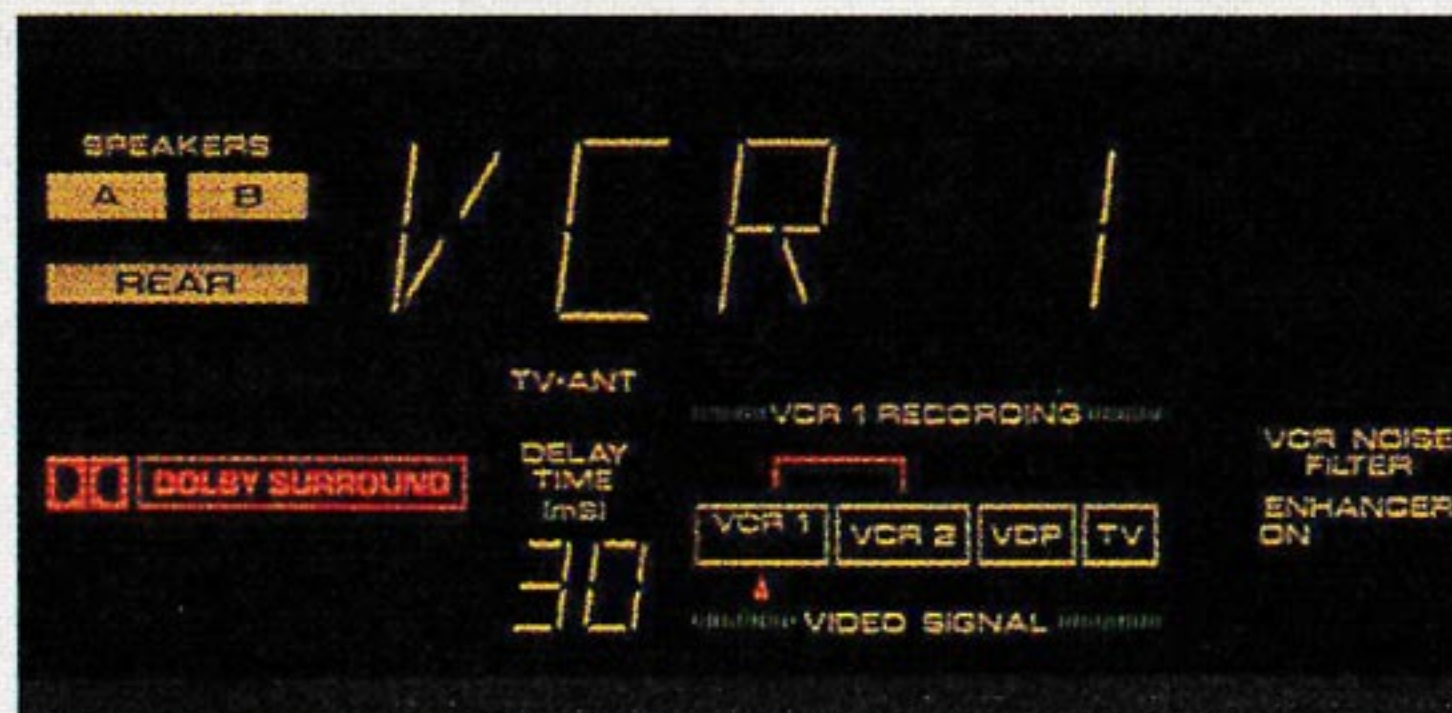

Large Multi-Information FL Display

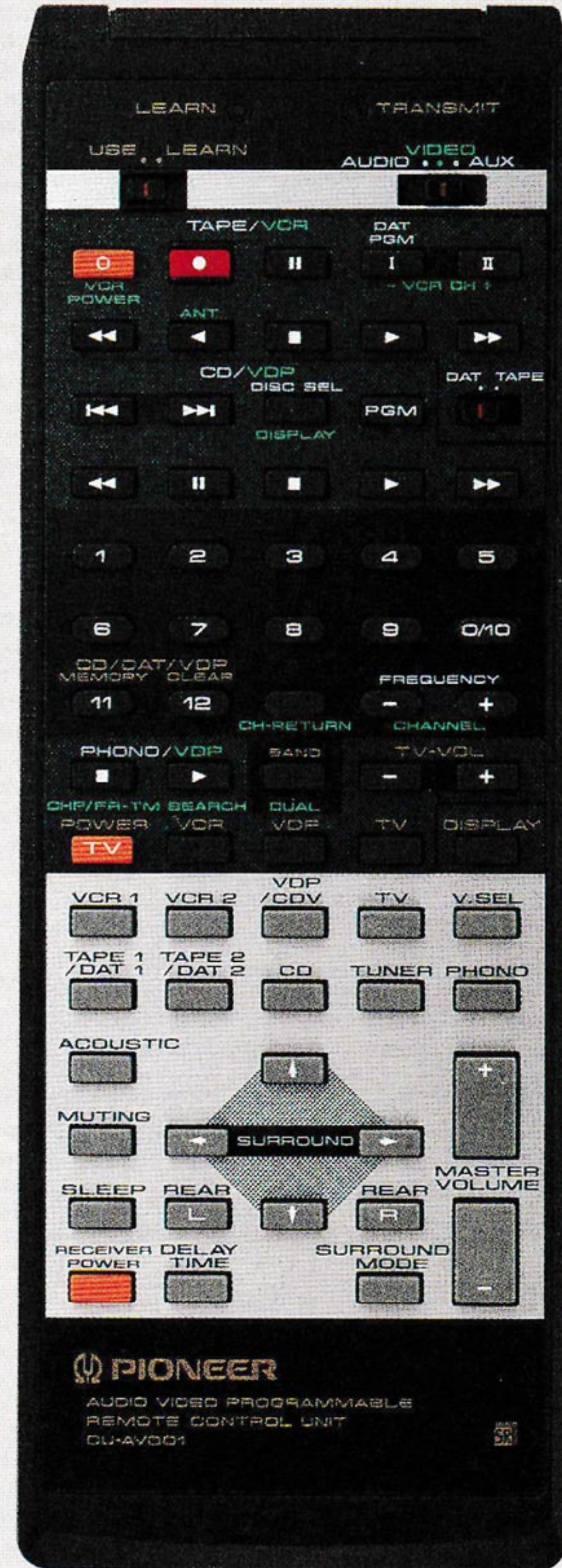

AV SR "Smart Remote"™ for VSX-7300S

## Pioneer SR System

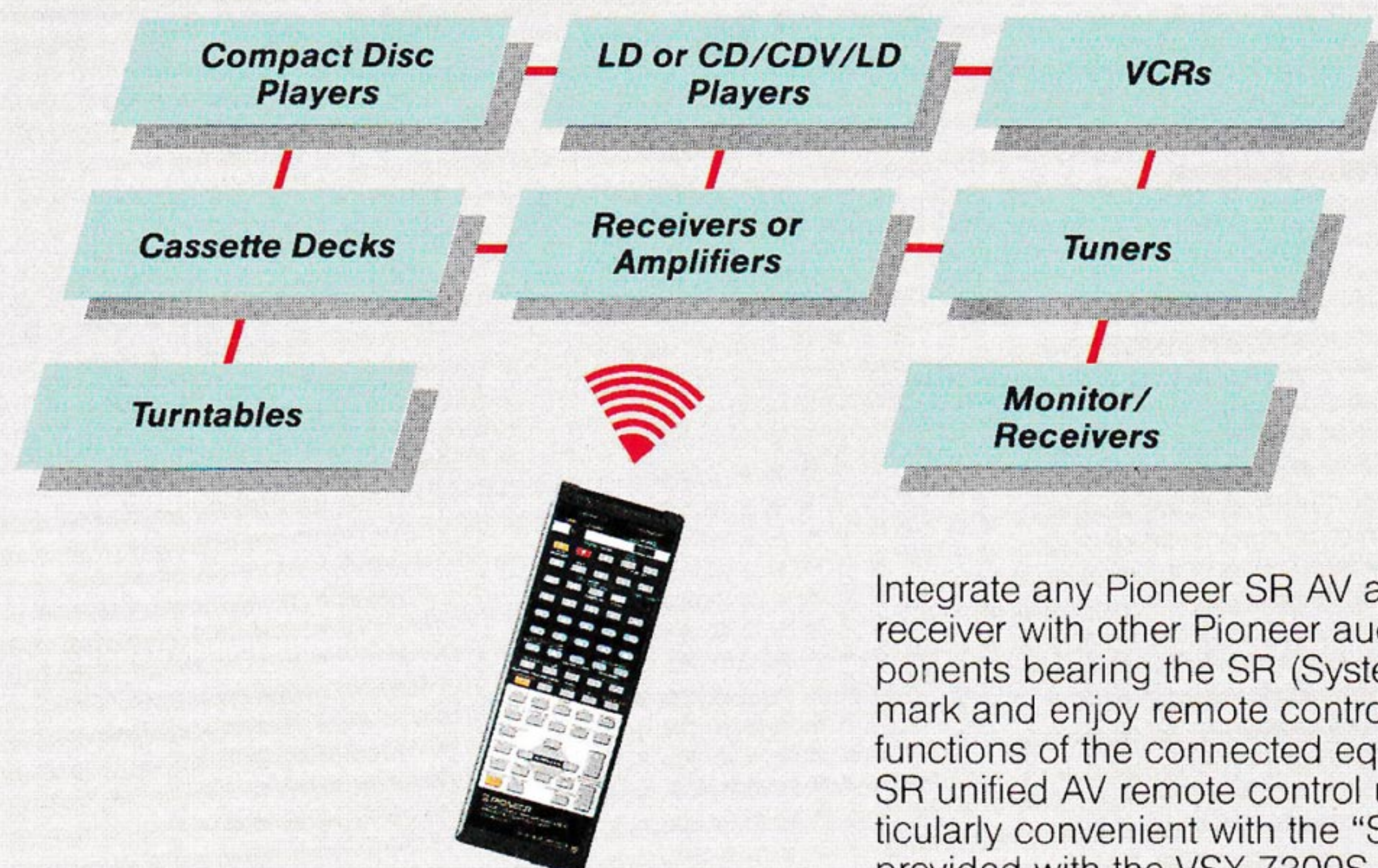

This mark indicates the compatibility for the Pioneer System Remote control.

Integrate any Pioneer SR AV amplifier or AV receiver with other Pioneer audio-video components bearing the SR (System Remote) mark and enjoy remote control of the main functions of the connected equipment from the SR unified AV remote control unit. This is particularly convenient with the "Smart Remote"™ provided with the VSX-7300S AV receiver, VSA-910 or C-90S amplifiers. This type of remote control is programmable to let you control the major functions of non-Pioneer audio/video components.



SR NON SWITCHING AMP™ DD DOLBY SURROUND™ SURROUND NTSC

AAFES CATALOG  
CRC No. 9284514

## VSX-7300S

Audio/Video Quartz-Synthesizer Receiver with AV "Smart Remote"™

- **Front Power:** Continuous average power output of 125 watts\* per channel, min., at 8 ohms, from 20Hz to 20,000Hz with no more than 0.005% total harmonic distortion
- **Rear Power:** 30 watts per channel, min., at 8 ohms, 1,000Hz with no more than 0.7% total harmonic distortion (surround)
- **Non-Switching™ Circuit Type II:** Ends switching distortion, improves linearity and thermal stability.
- **AV SR "Smart Remote"™:** Not only controls virtually every function of the VSX-7300S, but also the major functions of other SR components and, with its "Learning" capability, those of many non-Pioneer components.
- **Built-In Digital Surround Sound Processor:** DOLBY SURROUND, STADIUM and SIMULATED SURROUND with Digital Delay Circuit (15/20/30msec).
- **Motorized Volume Control:** Provides smooth, notch-free, non-electronic control of output level (volume) from Remote Controller.
- **Video Inputs:** Inputs for LD/CDV player, TV, VCR-1 and VCR-2, plus Adaptor in/output; dubbing is possible between VCRs, or from LD player to VCR; with Video Signal Selector and VCR Noise Filter
- **Audio Inputs:** CD, PHONO, DAT, TAPE 1 and 2.
- **Video Enhancer with Split Screen:** Brighter picture for viewing and dubbing; compare enhanced with non-enhanced picture on same screen.
- **REC Video Enhancer:** When dubbing to VCR 1, it enables you to enhance pictures while you watch the other video source.
- **Acoustic Memory:** Set five different bass/treble curves and recall any at a touch.
- **3 Speaker Terminals:** A, B and Surround
- Random Preset of 30 FM/AM Stations
- HIT (Hyper Intelligent Tuning) FM/AM Station Search
- Large Multifunction Fluorescent Display

\*Measured pursuant to the Federal Trade Commission's Trade Regulation Rule on Power Output Claims for Amplifiers.



VSX-7300S: For multiple applications as an AV control center with a multifunctional SR "Smart Remote"™.

### Feature Comparison

	VSX-7300S	VSX-5300	VSX-3300
<b>Power Output</b>			
Front (20 - 20kHz) (T.H.D.)	125W/ch. 0.005%	100W/ch. 0.005%	80W/ch. 0.05%
Rear	30W	15W	—
<b>Motorized Volume</b>	○	○	○
<b>Acoustic Memory</b>	○	○	○
<b>5-Band Graphic Equalizer</b>			○
<b>Surround</b>	Digital	Digital	
Dolby	○	○	
Stadium	○	○	
Simulated Surround	○	○	
<b>Speaker Matrix</b>			○
<b>Simulated Stereo</b>	○	○	○
<b>Audio Inputs</b>	Phono, CD, DAT/Tape 1, Tape 2	Phono, CD, DAT/Tape 1, Tape 2	Phono, CD, Tape 1, Tape 2
<b>Video Inputs</b>	VCR 1 & 2, LD/CDV, Adaptor	VCR 1 & 2, LD/CDV	LD/CDV, VCR
<b>VCR 2-Way Dubbing</b>	○	○	
<b>Simultaneous VCR Recordings</b>	○		
<b>Video Enhancer/Split Screen</b>	○	○	
<b>REC Video Enhancer</b>	○		
<b>Video Signal Selector</b>	○	○	○
<b>VCR Noise Filter</b>	○	○	
<b>FM/AM Random Station Preset</b>	30	30	24
<b>HIT Station Search</b>	○		
<b>Station Preset Scan</b>	○	○	○
<b>Large FL Display</b>	○	○	○
<b>Name-In</b>	○	○	
<b>AV SR Remote Control</b>	"Smart Remote"™	○	○

## VSX-5300



AAFES

CRC No. 9284712

## VSX-3300



AAFES CATALOG

CRC No. 9284126

**SR** NON SWITCHING AMP™

### VSX-5300 **DOLBY SURROUND™** **SURROUND** **NTSC**

#### Audio/Video Quartz-Synthesizer Receiver with Multi-function SR Remote Control

- **Front Power:** Continuous average power output of 100 watts\* per channel, min., at 8 ohms, from 20Hz to 20,000Hz with no more than 0.005% total harmonic distortion
- **Rear Power:** 15 watts per channel, min., at 8 ohms, 1,000Hz with no more than 0.7% total harmonic distortion (surround)
- **Non-Switching™ Circuit Type II:** Ends switching distortion, improves linearity and thermal stability.
- **Multifunction AV Remote Control Unit:** Controls virtually every function of the VSX-5300, and the major functions of other SR components.
- **Built-In Surround Sound Processor:** DOLBY SURROUND+, STADIUM and SIMULATED SURROUND with Digital Delay Circuit (15/20/30msec).
- **Motorized Volume Control:** Provides smooth, notch-free, non-electronic control of output level (volume) from Remote Controller.
- **Video Inputs:** Inputs for LD/CDV player, TV, VCR-1 and VCR-2; dubbing is possible between VCRs, or from LD player to VCR; with Video Signal Selector and VCR Noise Filter.
- **Audio Inputs:** CD, PHONO, DAT, TAPE 1 and 2.
- **Video Enhancer with Split Screen:** Brighter picture for viewing and dubbing; compare enhanced with non-enhanced picture on same screen.
- **Acoustic Memory:** Set five different bass/treble curves and recall any at a touch.
- **3 Speaker Terminals:** A, B and Surround
- Random Preset of 30 FM/AM Stations
- Large Multifunction Fluorescent Display

\*Measured pursuant to the Federal Trade Commission's Trade Regulation Rule on Power Output Claims for Amplifiers.

### VSX-3300 **SR** **SURROUND**

#### Audio/Video Quartz-Synthesizer Receiver with Graphic Equalizer

- **Continuous average power output of 80 watts\* per channel, min., at 8 ohms, from 20Hz to 20,000Hz with no more than 0.05% total harmonic distortion**
- **Built-In Graphic Equalizer:** Center frequencies at 100Hz, 330Hz, 1kHz, 3.3kHz and 10kHz; with Defeat Switch
- **Multifunction AV Remote Control Unit:** Controls connected AV components.
- **Sound Processor:** For speaker-matrix surround-sound effects.
- **Motorized Volume Control:** Provides smooth, notch-free, non-electronic control of output level (volume) from Remote Controller.
- **Video Inputs:** Inputs for LD/CDV player, VCR and a TV.
- **Audio Inputs:** CD, PHONO, TAPE 1 and 2.
- **Video Signal Selector:** Offers wide flexibility in recording, such as taping a video source with an independent audio source.
- **Random Preset of 24 FM/AM Stations:** Convenient for one-touch recalls.
- **Station Preset Scan:** For your convenience in finding your favorite tune.
- FM auto/mono switch
- Large Multifunction Fluorescent Display
- 2 Switched, 1 Unswitched AC Outlets

### JA-RF5 NTSC

#### RF Modulator

This simple unit converts baseband video signals from the VSA-910, the three VSX receivers or the C-90S into RF signals for the antenna input of a regular TV.



AAFES CATALOG

CRC No. 9462003

# Amplifiers

## Pioneer Technology at Work in Amplifiers

### The Pioneer AV Concept

It's simple. Simple to explain — simpler to use. Providing sophisticated control of audio (the "A" in "AV") is old stuff. Now, the "V" for video has joined the picture in Pioneer AV products such as our VSA-910 Audio-Video Amplifier and top-of-the-line C-90S Audio-Video Control Preamp. Either component serves as the "headquarters" for all your AV needs. Multiple video inputs/controls let you dub between video decks, record from any video-signal source (tuners, cameras, computers, etc.) and compare the effects of enhancing, etc. The same goes for the multiple audio inputs/controls which work with video-derived audio signals as well. With the "Smart Remote™" (see later pages for details), it's easier than ever. And there you have it — putting "A" with "V" for the TOTAL Pioneer AV concept.

### Anti-Resonance Design

Not too long ago it was fashionable among audiophiles to weigh down their amps and other components with bricks, slabs of marble, even specially designed lead cabinet covers. Odd as it seems, putting something heavy atop a working hi-fi component did have some value: it helped to damp certain kinds of physical vibrations generated inside the component by electric and electronic parts — vibrations that could have appreciable bad effect on sound quality.

The "put-a-brick-on-it" didn't always work, though it was a step in the right direction. But not to worry — Pioneer has taken a lot more steps on the same path and come up with our "Anti-Resonance" design policy. We don't use heavy weights, but something far more sensible: Honeycomb Stiffeners. They accomplish the same thing, but even more so. This special ribbed "honeycomb" design in the materials used in key points — such as the chassis, separators, heat sinks, insulators, etc., increases rigidity and discourages internal and external vibration — for a purer, more "transparent" sound.

### Shielded Circuitry

To further sound purity, we also employ shielded circuitry wherever possible. This means that individual circuit and power-supply blocks have been separated from their neighbors by thick, diecast aluminum cases, especially where physical and/or electronic/magnetic emissions, such as from the power supply, could cause problems.



Honeycombed Heat Sink

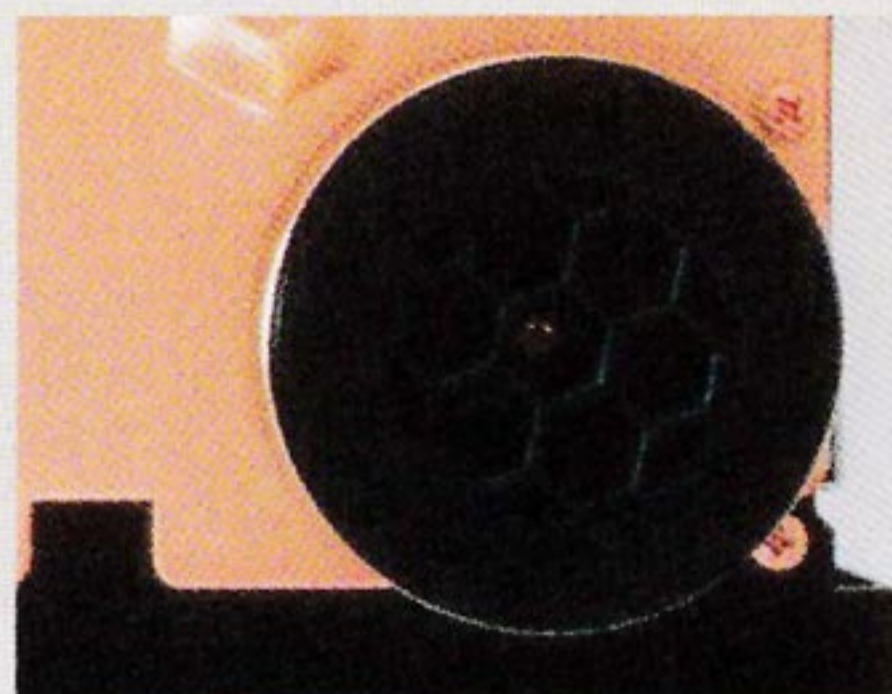

Honeycombed Insulator

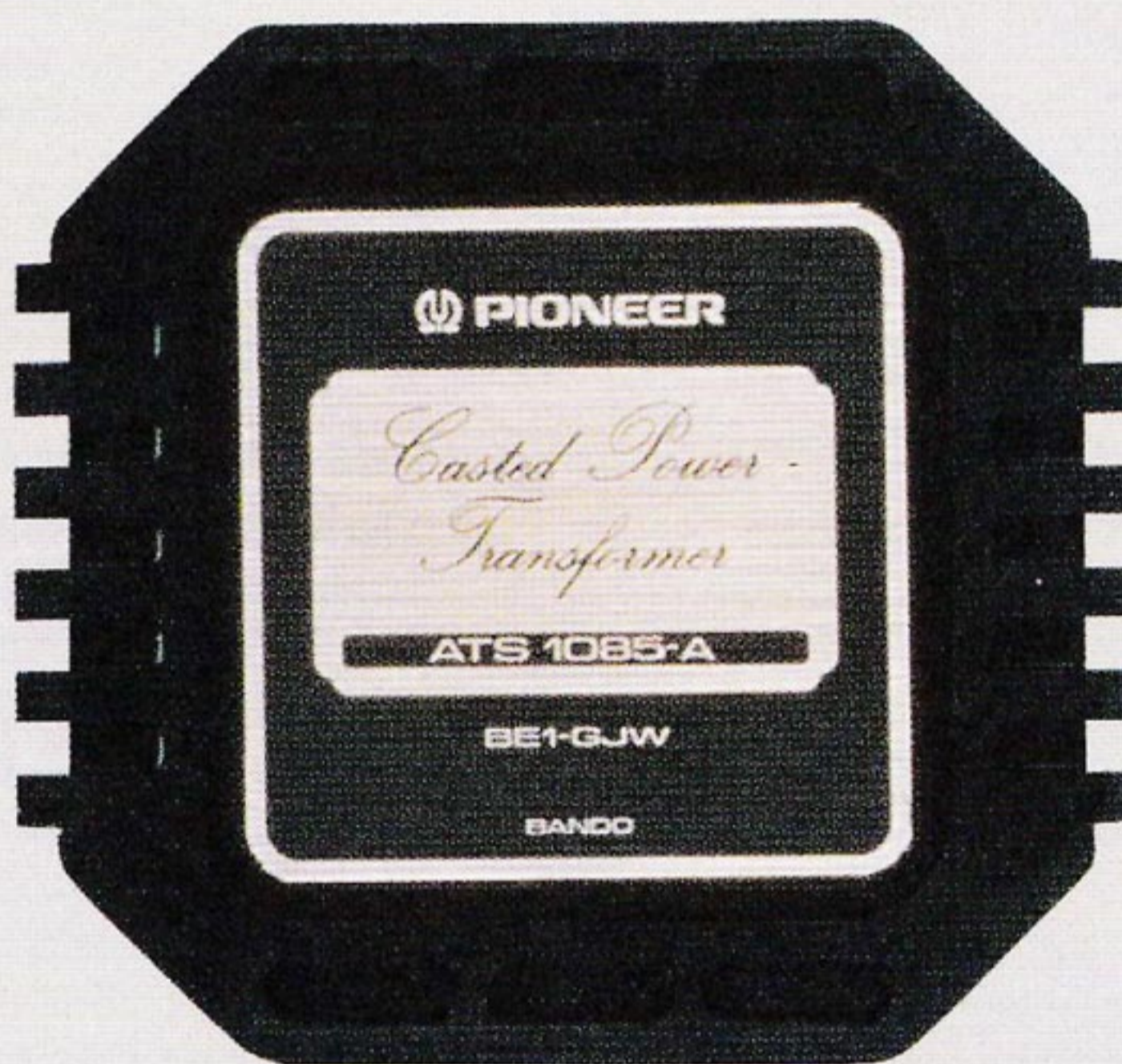

Bipolar Transformers:  
Cast-iron covers damp resonance.

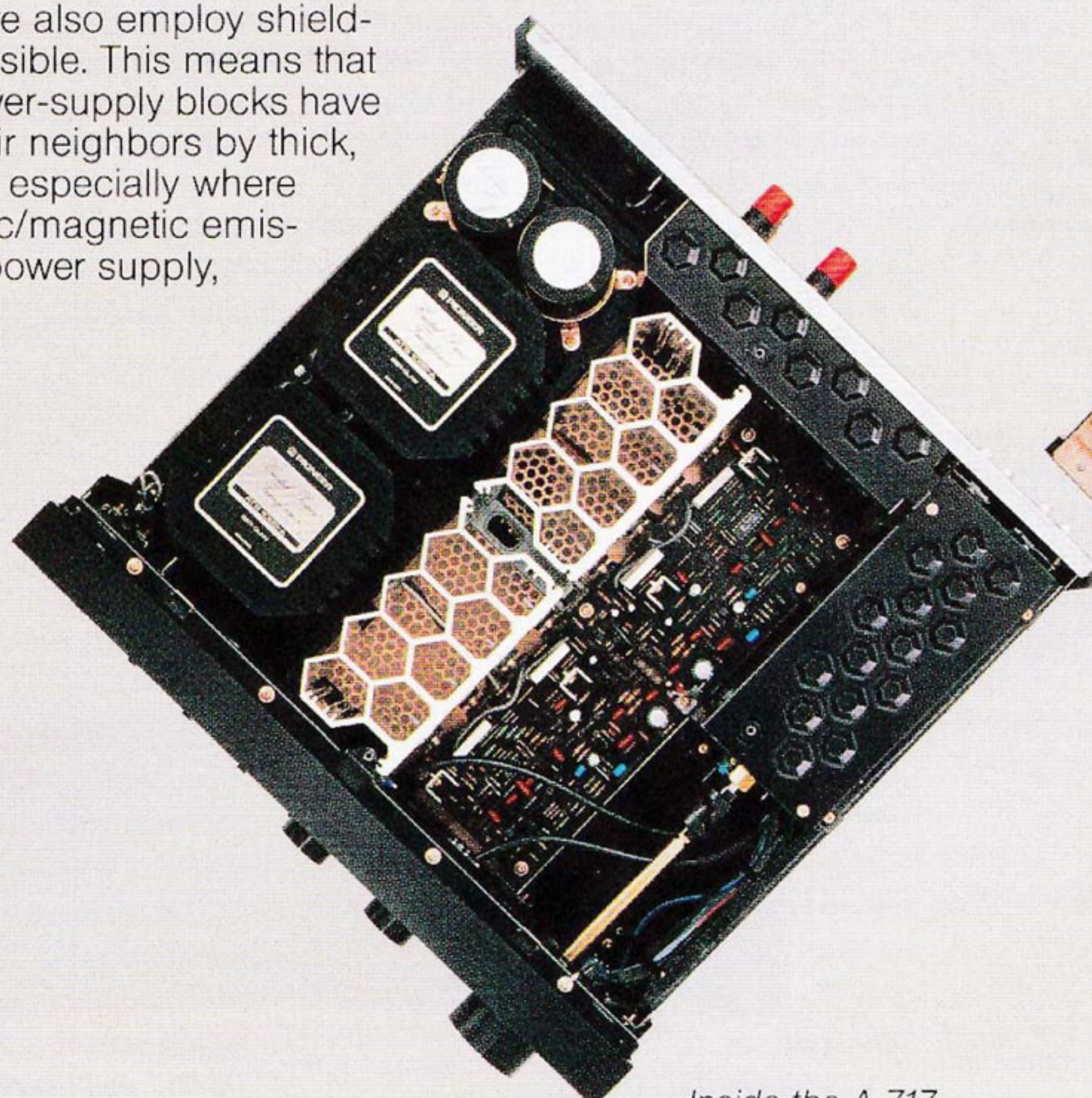

Inside the A-717

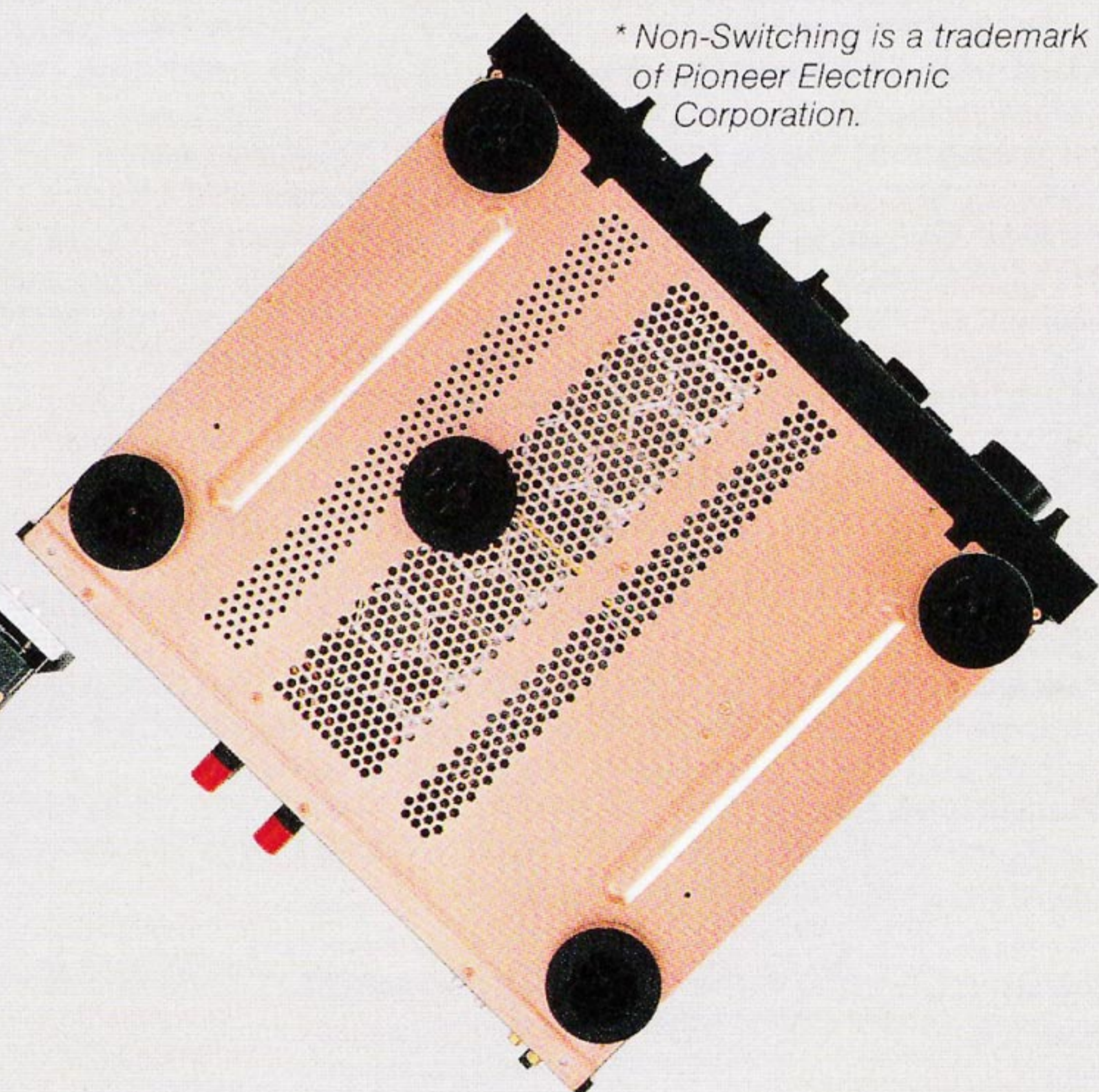

Honeycombed Baseplate (A-717)

### Direct Circuit Connection (Short-Path Signal Routing)

Wherever possible (even when it means relocating a front-panel switch or two), the working circuits inside each component are positioned so as to shorten the overall length of the path the signals must travel from input to output. While the practical examples of this Pioneer approach are far too numerous to mention here, some of the specific "Short-Path" designs of interest to careful shoppers are the Direct switch in the A-717 and A-616 which puts all secondary circuits except volume off-line to ensure purest sound possible, and the special designs in the M-90 for CD, such as Direct CD Input and CD Level Control and its CD Output Loop.

In the top-end C-90S and M-90 components, this philosophy is taken a step further by creating a true "Monophonic-times-Two" configuration in which virtually all the circuitry and power-supply support for one channel is totally independent from that of the other channel.

Along this design policy, the A-717's phono section has an "Independent Power Switch." It turns the phono off when not in use to cancel its electrical interference to signals from other music sources.

### Pioneer Non-Switching™ Amplifiers

The power-output stages of the best Pioneer power amplifiers, integrated amplifiers and receivers employ an exclusive design we call Non-Switching.\* This Pioneer-developed technology totally eliminates switching distortion for a cleaner sound. The M-90 and VSA-910 have Non-Switching™ Type II, which stabilizes idle-current fluctuation and reduces thermal distortion. The distortion in Non-Switching™ ICs is reduced to 1/30th usual. In the A-717, the latest Type III version is provided to achieve an improved low-impedance drive capability with a better response in handling a surge of larger currents. New ICs have distortion further reduced to 1/50 the original value.

\*Non-Switching is a trademark of Pioneer Electronic Corporation.

# C-90S



CATALOG

CRC No. 9286113

## C-90S SR NTSC

### Reference Control Amplifier with AV "Smart Remote™"

- **"Mono x Two" Design Concept:** Audio circuitry in the respective channels is entirely separated, independently grounded and individually supplied with power from separate windings on one of the two power transformers.
- **Audio/Video Independence:** Circuitry for video-only use is well isolated from other parts, and fed power from a transformer dedicated to video/display functions.
- **Short-Path Design:** Lessens the chance that even the tiniest electrical or magnetic radiation within can harm the delicate signals.
- **Copper-Plated Chassis and Screws:** Reduce magnetic distortion.
- **"Hybrid" MC Transformer/Phono Amp:** For flat response and less noise.
- **AV SR "Smart Remote™":** Not only controls virtually every function of the C-90S, but also the major functions of other SR components and, with its "Learning" capability, those of many non-Pioneer components.
- **Motorized Volume Control:** Provides smooth, notch-free, non-electronic control of output level (volume) from Remote Controller.
- **6 Audio and Video Inputs:** CD, phono, tuner, two decks and adaptor (audio) and an LD player, three VCRs, TV/Video and adaptor (video).
- **Video Outputs:** Two monitor outputs, and a 5-pin RF converter output.
- **REC Selector:** Offers wide flexibility in recording/dubbing, such as taping a video source with an independent audio source, and independent use of adaptors (audio/video) while recording.
- **Dubbing Circuits (Audio):** Dub between Deck A and Deck B in either direction, or record audio portion of any video source.
- **Dubbing Circuits (Video):** Dub TV/VDP to any or all three connected VCRs (Parallel Copy) with video-and-audio, video-only or audio-only; Two-Way Dubbing from any of three VCRs to either or both of the others; dubbing can be made while viewing/listening to other programs.
- **Video Enhancer:** Switch on to enhance any video signal sent to monitor(s) and/or connected decks for recording/dubbing. Sharpness, Detail and Noise Reduction controls are provided.
- **Luxurious Finish:** Thick aluminum front panel with deep black, lacquer-like luster, gold-toned highlights and beautiful rosewood-grained side panels, matching M-90.

\*Measured pursuant to the Federal Trade Commission's Trade Regulation Rule on Power Output Claims for Amplifiers.

## M-90 NON SWITCHING AMP™

### Reference Power Amplifier

- **Continuous average power output of 200 watts\* per channel, min., at 8 ohms, from 20Hz to 20,000Hz with no more than 0.003% total harmonic distortion:** Can deliver dynamic power of 800 watts at 2 ohms (with EIA dynamic test signal).
- **"Mono x Two" Design Concept:** Each channel is treated like a single, monophonic line from input to output. Each has its own power supply, very large, heavy transformer, transistor bank, heat sink, etc. To handle massive current flow, high-electrolytic capacitors (total 48,000µF) offer a capacity of as much as 47A of current.
- **Low-Impedance Drive:** Improves response accuracy when sharp-attack signals are present, such as when playing digital sources.
- **Short-Path Design:** Lessens the chance that even the tiniest electrical or magnetic radiation within can harm the delicate signals.
- **Non-Switching™ Circuit Type II:** Ends switching distortion, improves linearity and thermal stability.
- **Direct Input for CD:** Analog signal can be sent directly to power-amplification stages via input on back panel.
- **Volume Control for CD:** Also "short-path" in design, it is linked to the potentiometer behind the input terminals via a stiff shaft.
- **CD Output Loop:** Route CD input back to any connected pre-amp for listening/recording.
- **Luxurious Finish:** Thick aluminum front panel with deep black, lacquer-like luster, gold-colored highlights, large power indicators and beautiful rosewood-grained side panels, matching C-90S.

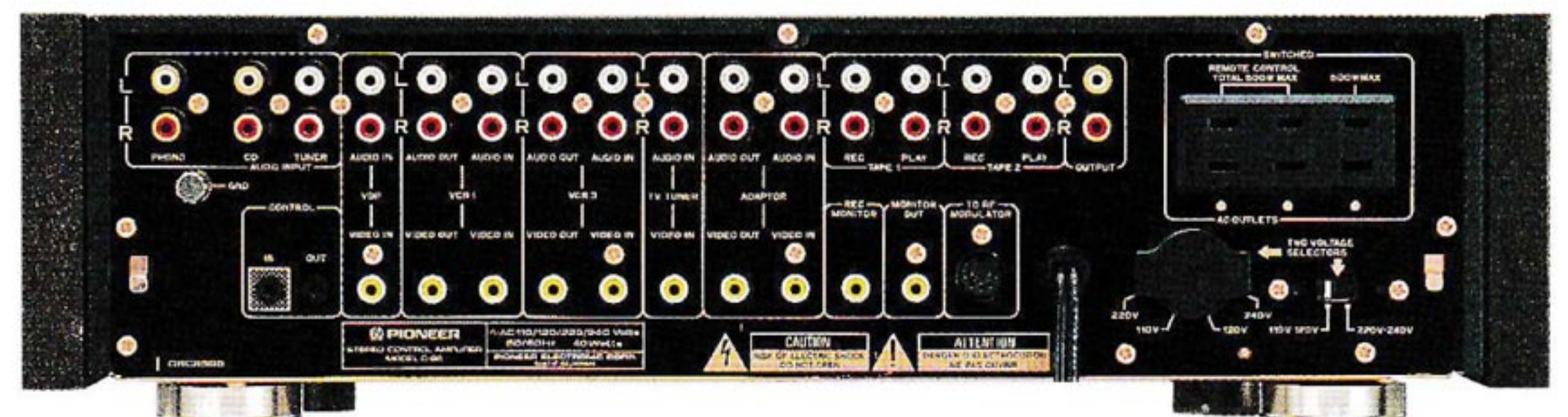

C-90S: For multiple applications as an AV control center with a multifunctional AV SR "Smart Remote™"

# M-90



CATALOG

CRC No. 9751926

Amplifiers



## A-717 NON SWITCHING AMP™

### Non-Switching™ Integrated Amplifier

- **Continuous average power output of 100 watts\*** per channel, min., at 8 ohms, from 20Hz to 20,000Hz with no more than 0.003% total harmonic distortion (140 watts\* at 4 ohms with 0.005% T.H.D.)
- **Direct Circuit Connection:** Short-path design for the purest possible sound.
- **Anti-Resonance Design:** Honeycombed material defeats local resonance in chassis, separators, heat sinks and large insulators cancel external vibrations.
- **High-Capacity Bipolar Transformers:** Clarity is preserved since separate design and solid cast cases damp resonance and lower magnetic flux.
- **Separate Circuit Blocks:** High-quality construction lessens noise, etc.
- **“DIRECT” Switch:** Puts all secondary circuits except volume off-line to ensure purest sound possible.
- **Non-Switching™ Circuit Type III:** Ends switching distortion, improves linearity, thermal stability and low-impedance handling.
- **Separate Voltage-/Output-Amp Stages:** Ensuring consistent performance regardless of load variations.
- **8 Inputs:** CD, TAPE, PHONO, etc.
- High-Gain Phono Equalizer
- Independent Power Switch for Phono
- Gold-Plated Phono and CD Inputs



## A-616 NON SWITCHING AMP™

### Non-Switching™ Integrated Amplifier

- **Continuous average power output of 80 watts\*** per channel, min., at 8 ohms, from 20Hz to 20,000Hz with no more than 0.005% total harmonic distortion (100 watts\* at 4 ohms with 0.008% T.H.D.)
- **Direct Circuit Connection:** Short-path design protects sound purity.
- **Anti-Resonance Design:** Honeycombed material defeats local resonance in chassis, separators, heat sinks and large insulators cancel external vibrations.
- **High-Capacity Transformer:** Clarity is preserved since solid cast case damps resonance and lowers magnetic flux.
- **Separate Circuit Blocks:** High-quality construction lessens noise, etc.
- **“DIRECT” Switch:** Puts all secondary circuits except volume off-line to ensure purest sound possible.
- **Non-Switching™ Circuit Type II:** Ends switching distortion, improves linearity and thermal stability.
- **8 Inputs:** CD, TAPE, PHONO, etc.
- High-Gain Phono Equalizer
- Gold-Plated Phono and CD Inputs

\* Measured pursuant to the Federal Trade Commission's Trade Regulation Rule on Power Output Claims for Amplifiers.



AAFES CATALOG  
CRC No. 9370313

SR NON SWITCHING AMP™ DOLBY SURROUND™ SURROUND NTSC

## VSA-910

### Audio/Video Digital Surround Amplifier with AV "Smart Remote"™

- **Stereo mode:** Continuous average power output of 100 watts\* per channel, min., at 8 ohms, from 20Hz to 20,000Hz with no more than 0.005% total harmonic distortion
- **Surround mode:** Continuous average power output of 70 watts\* per channel, min., at 8 ohms, from 20Hz to 20,000Hz with no more than 0.005% total harmonic distortion (front); 30 watts\* per channel, min. at 8 ohms, from 20Hz to 20,000Hz with no more than 0.08% total harmonic distortion (surround)
- **Non-Switching™ Circuit Type II:** Ends switching distortion, improves linearity and thermal stability.
- **AV SR "Smart Remote"™:** Not only controls virtually every function of the VSA-910, but also the major functions of other SR components and, with its "Learning" capability, those of many non-Pioneer components.
- **Built-In Surround Sound Processor:** DOLBY SURROUND+, STADIUM and SIMULATED SURROUND.
- **Digital Delay Circuit:** Three delay positions (15/20/30msec) are provided. Digital processor ensures low-noise performance.
- **4 Video Inputs:** Inputs for LD player, TV, VCR-1 and VCR-2, plus Adaptor in/output; dubbing is possible between VCRs, or from LD player to VCR.
- **Audio Inputs:** CD, PHONO, TUNER, DAT, TAPE.
- **Video Enhancer with Split Screen:** Brighter picture for viewing and dubbing; compare enhanced with non-enhanced picture on same screen.
- **Acoustic Memory:** Set three different bass/treble curves and recall any at a touch.
- **Super Bass:** Deepens acoustic field by enhancing low-bass frequencies.
- **On-Screen Display:** Operational status of the amplifier at a glance.
- **Large Multifunction Fluorescent Display**

\* Measured pursuant to the Federal Trade Commission's Trade Regulation Rule on Power Output Claims for Amplifiers.  
+ "Dolby Surround" and the double-D symbol are trademarks of Dolby Laboratories Licensing Corporation.

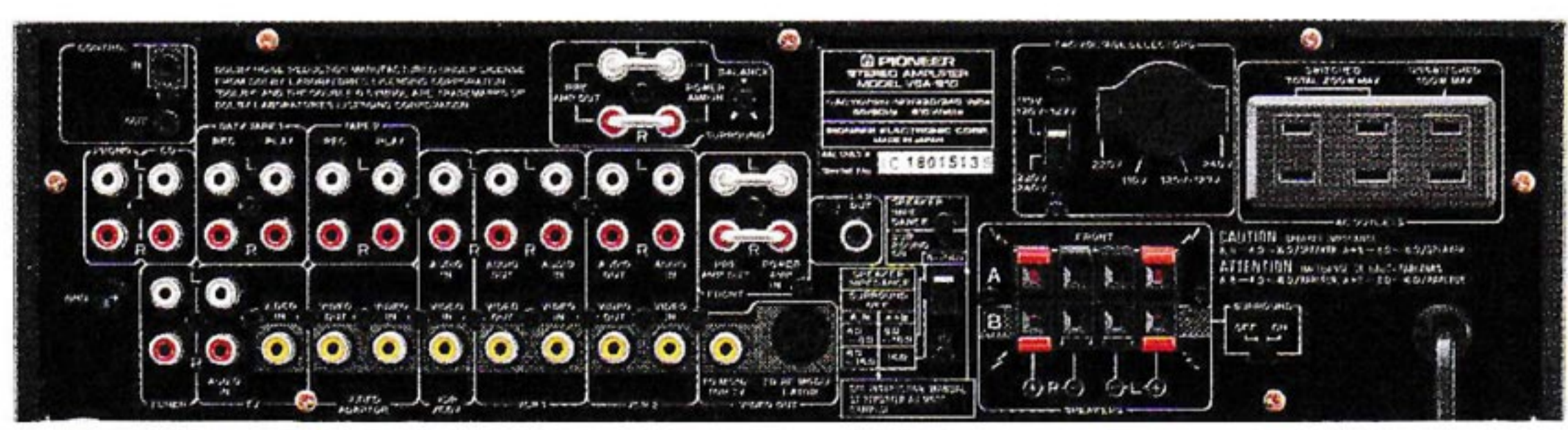

### Get the AV "Smart Remote"™

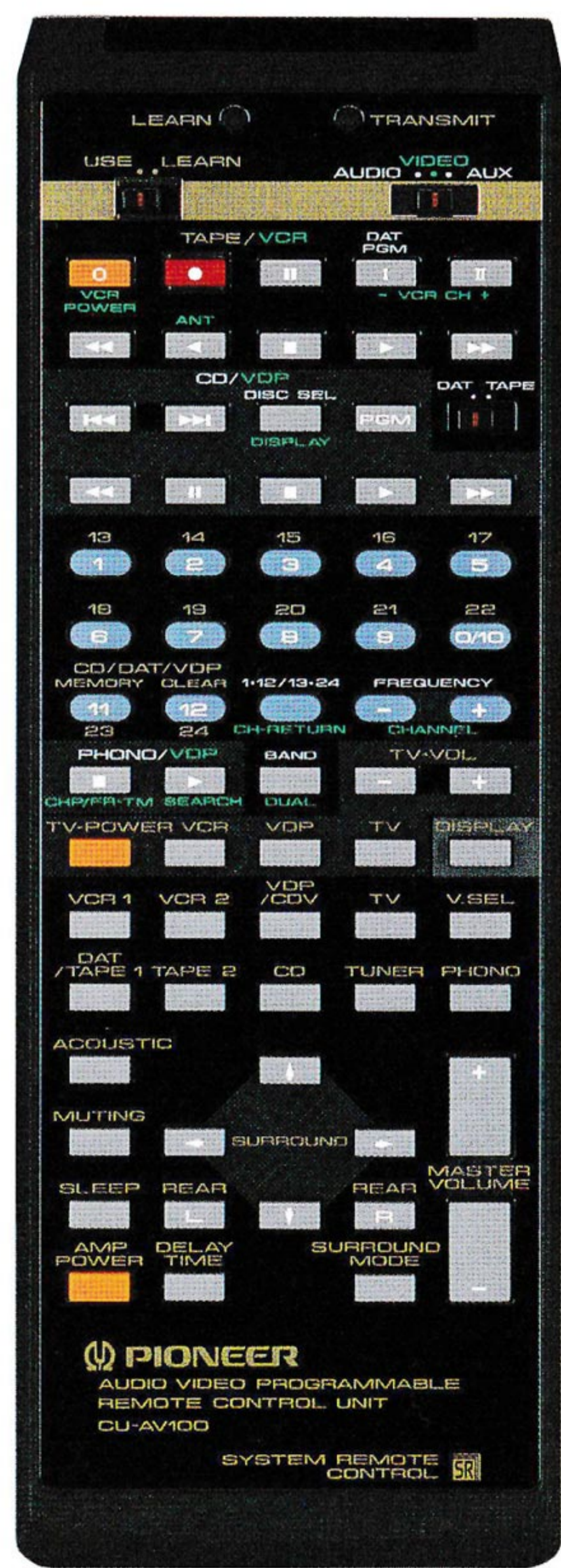

- "Learning" Capability
- Total AV Control
- Video Controls: LD/CDV, TV, VCR-1 & 2, and Adaptor
- Audio Controls CD, Phono, DAT and Cassette Deck
- Total Surround Control
- Volume and Acoustic Memory



# Tuners

## F-91



CATALOG

CRC No. 9374513

## F-443



AAFES CATALOG

CRC No. 9286006

## F-91 SR

### Reference Digital Synthesizer Tuner

- **Pioneer-Exclusive ARTS (Active Real-Time Tracing System):** Tuned frequency is followed in real time by IF filter circuit to eliminate interference and pass on purest possible signal to audio output.
- **Pioneer's Digital Direct Decoder Type III:** Every major tuner specification is improved through digital processing combined with direct conversion from FM to left/right audio output.
- **Anti-Resonance Design:** Honeycombed material and large insulators defeat external vibrations for cleaner sound.
- **ID MOS FET in FM Front End:** Enables lower noise and distortion, higher sensitivity and better interference rejection.
- **Random Presets for 24 FM/AM Stations:** Preset and recall favorite stations at a touch.
- **Auto Level Indicator**
- **REC Level Check:** A convenience when recording off the air.
- 3-Step Muting
- 3-Station Timer Programming
- Large Fluorescent Display

## F-443 SR

### Quartz-PLL FM/AM Tuner

- **Silent-Servo Circuit:** Maintains clean and clear signal reception; once the frequency from a certain station is tuned in, the synthesizer tuner lets incoming signals bypass the PLL and the microprocessor circuits, switching off the power of those circuits. This design cancels beat noise, otherwise generated by quartz timing devices in those circuits, and avoids the generation of annoying ripple noise from vibrations of the PLL.
- **Pioneer CCTS (Computer-Controlled Tuning System):** Automatically minimizes tracking error for lower noise and distortion; the hi-blend circuit activates to reduce stereo noise when the signal is weak.
- **AM Servo Circuit:** Controls automatic gain to prevent a rise in distortion that might otherwise occur when receiving low-level signals.
- **Mode Memory:** On/off status of stereo/mono, AM servo and Silent servo circuits are maintained in onboard memory.
- **Random Presets for 24 FM/AM Stations:** Preset and recall favorite stations at a touch.
- Mono/Stereo Switch
- Digital Readout of Signal Strength

### ARTS Cleans Up Your Act

Pioneer's exclusive Active Real-Time Tracing System — ARTS for short — helps the F-91 deliver clean and optimum signal reception. It replaces the "WIDE/NARROW" filtering technique in which the WIDE position provided better sound quality at the expense of selectivity and, conversely, the NARROW position provided better selectivity at the expense of sound quality. Using a kind of "servo-filtering," its IF filter circuit traces the tuned frequency in real time, eliminating interference ONLY where it actually exists, thus providing optimum sound quality AND selectivity.

1 Interference

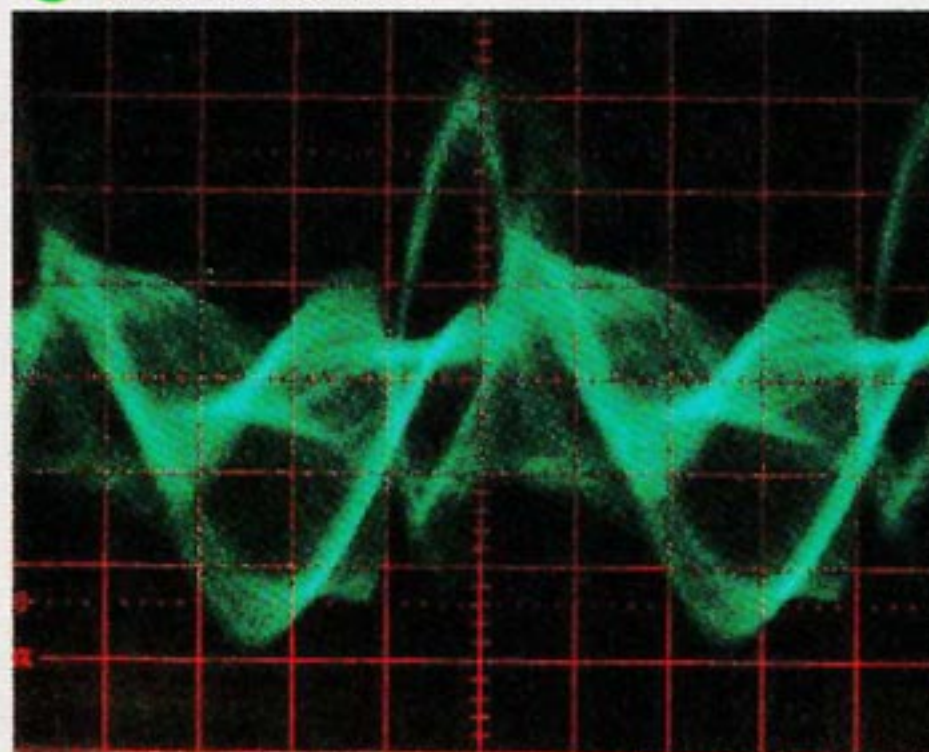

2 Distortion

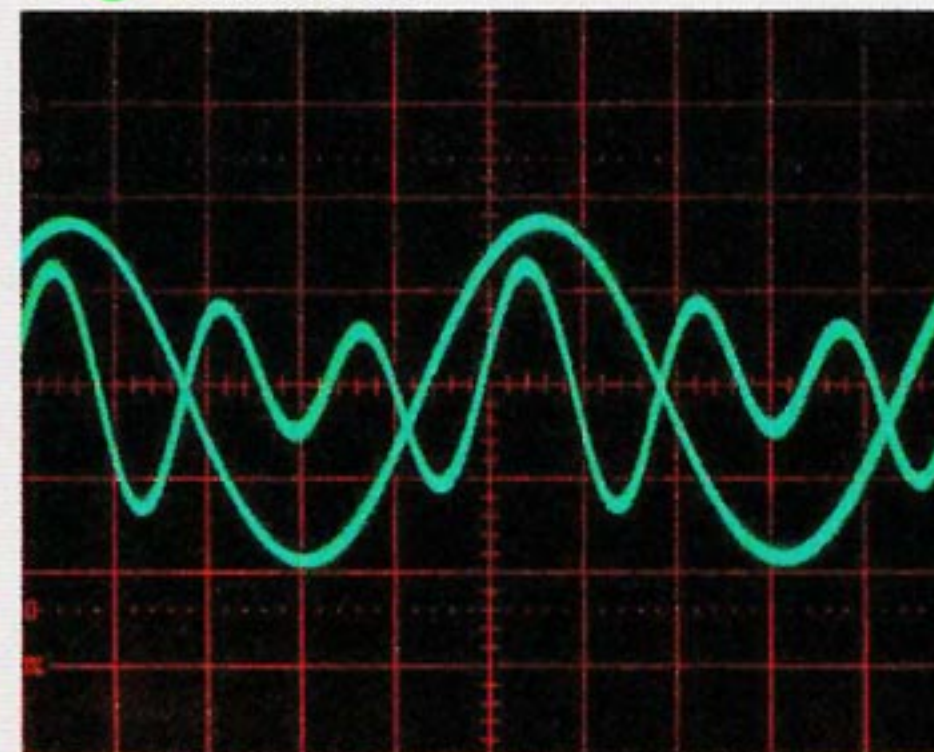

3 ARTS applied

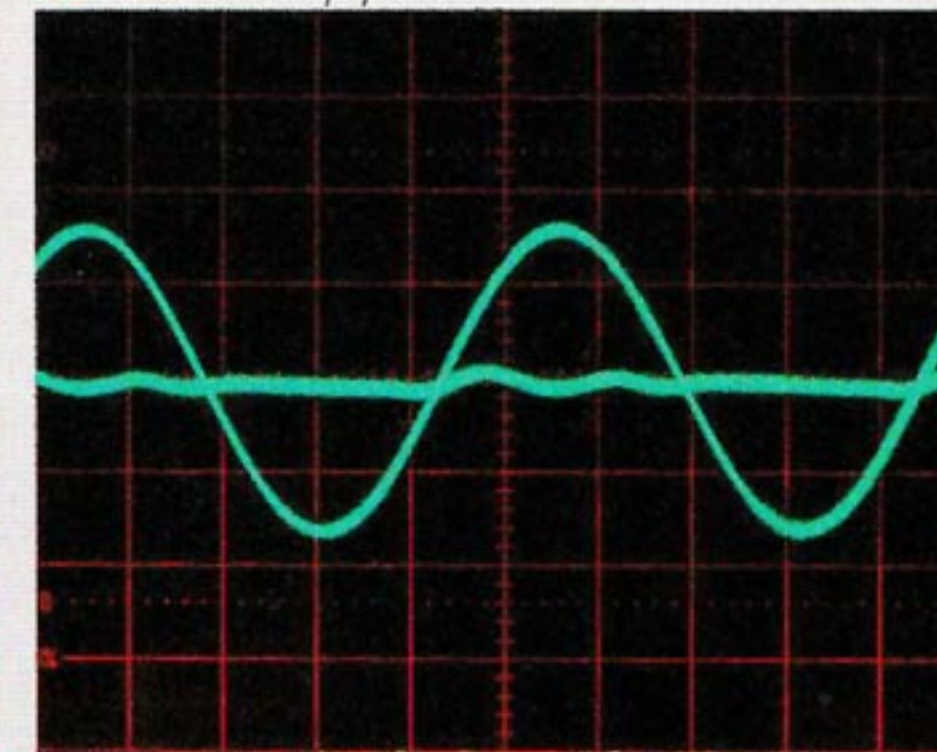

INTERFERENCE 1 affects tuner performance when a conventional wideband filter is used to maximize the frequency range of the tuned station. Conversely, DISTORTION 2 can result when a narrowband filter attempts to remove interference. Both distortion and interference are absent from the tuned signal 3 coming from the ARTS circuitry in the Pioneer F-91, giving you both the low distortion of a WIDE bandwidth and the high selectivity of a NARROW bandwidth at the same time.

# Cassette Decks



AAFES CATALOG  
CRC No. 9297508

## CT-W900R

### Twin Quick-Auto-Reverse Cassette Deck

- **Double Quick-Auto-Reverse REC/PLAY Cassette Transports:** Taping has never been easier.
- **Twin Dolby HX PRO\*:** Improves response in high frequencies and expands dynamic range.
- **Dolby B/C Noise Reduction\*:** Lowers "hiss," preserves dynamic range.
- **Pioneer Cassette Stabilizer:** Secures cassettes tight for stable operation.
- **Anti-Resonance Design:** Honeycomb Chassis defeats local resonance and Large Insulators cancel external vibrations.
- **Plentiful Power Supply:** A high-speed active servo regulator controls and assures a stable power supply for accurate reproduction of digital sources.
- **High-Quality Tape Heads:** OFC (oxygen-free copper) windings with high-quality low-impedance heads for improved signal-to-noise ratio.
- **Full-Logic Tape Transports:** Comfortable and jam-free.
- **Relay REC/PLAY:** Record or play second tape when first ends.
- **Parallel Recording:** Record two tapes at once.
- **Synchro-Start Dubbing:** At normal or double speed.
- **Auto REC Mute:** Records "cue-blanks" between songs.
- **Music/Skip Search:** Skip up to 15 songs in either direction.
- **Blank Skip/Blank Search:** Skip blank portions or find blank portions for play or recording.
- Auto Tape Selector and Timer Record/Play (with optional timer)
- MPX Filter Switch
- Headphone Output with Volume Control
- Large Multi-Information FL Display
- SR (System Remote) terminal

### Pioneer Cassette Stabilizer Design

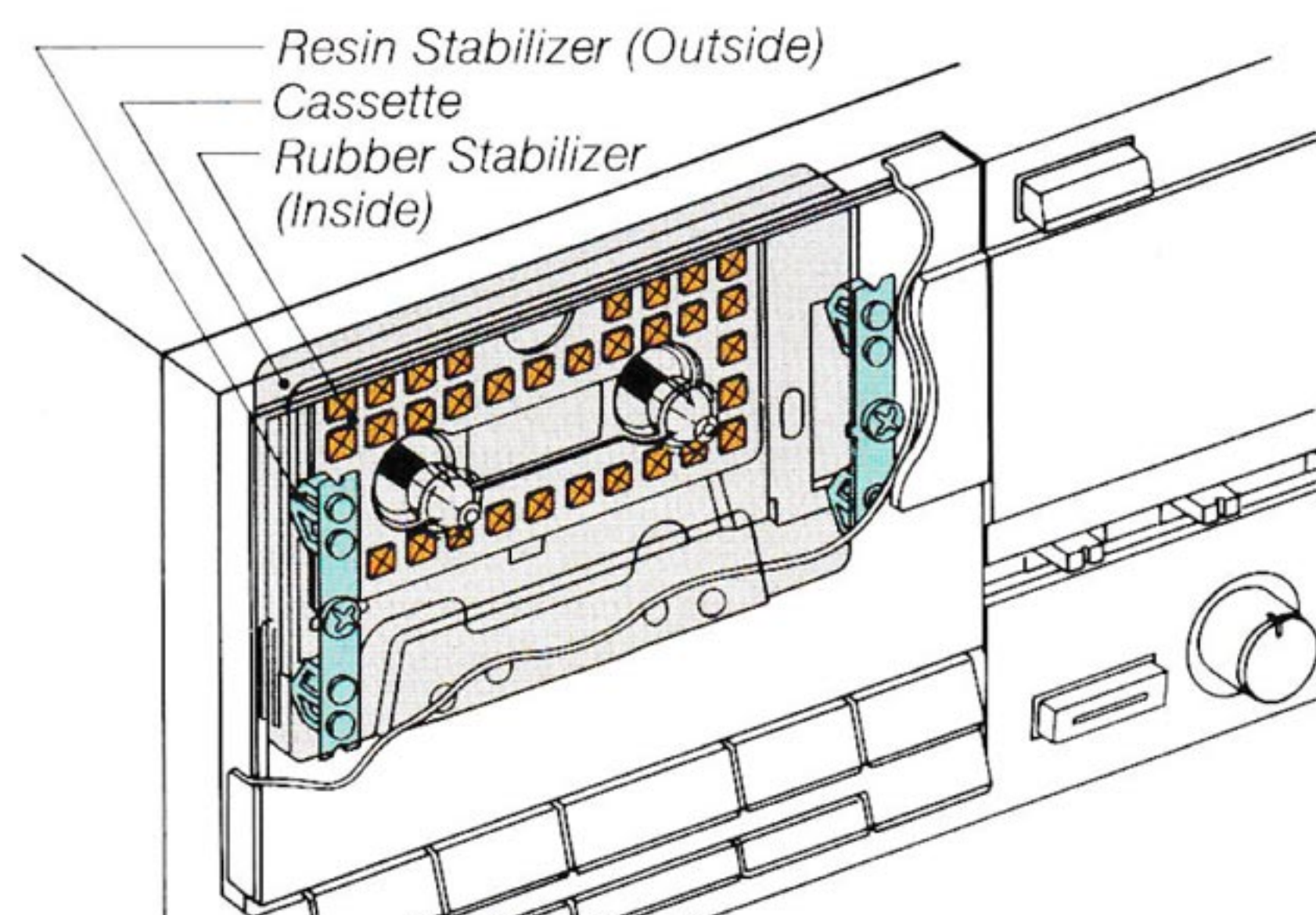

### Dolby HX PRO\*

Our top-of-the-line CT-W900R incorporates the Dolby HX PRO in both its cassette transports; the CT-W770R has it in one transport. This high-quality system was developed specifically to accurately record and reproduce signals, such as those from digital sources, that have powerful high-frequency content.

Typical cassette decks use alternating bias currents to assure recordings are made with optimum midrange-frequency performance in terms of distortion, sensitivity and maximum output level. In the face of very strong high-frequency inputs, however, such a system tends to work against itself, as the signal components themselves create an additional "bias".

Dolby HX PRO takes this into account, and automatically lowers bias current when a large quantity of high-frequency content is input. In short, this results in even better performance in the highs, without a corresponding deterioration of mid- and low-frequency response. It does so by detecting high-frequency components at the recording head, then controlling bias current accordingly.

Combined with a Dolby B or C, Dolby HX PRO dramatically improves response in higher frequencies and, equally important, expands dynamic range for impressive audible improvements, particularly with digital sources. But don't just take our word for it — listen to what Dolby HX PRO can do in a Pioneer deck.

### Improved Response with Dolby HX PRO

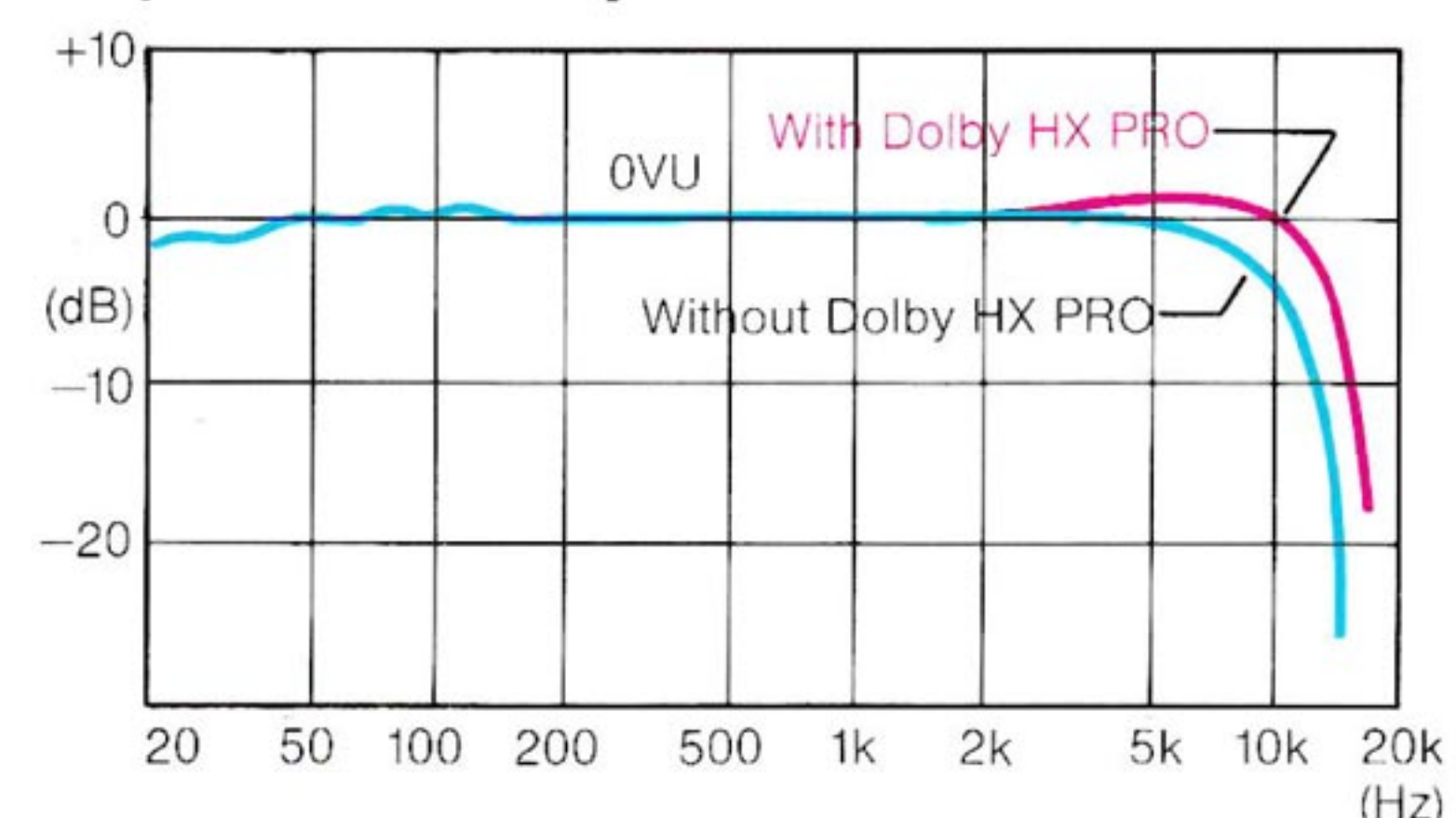

● Comparison is made with our conventional model not provided with Dolby HX PRO, using a normal-position tape.

\* Noise reduction and headroom extension manufactured under license from Dolby Laboratories Licensing Corporation. HX Professional originated by Bang and Olufsen. "Dolby" and the double-D symbol are trademarks of Dolby Laboratories Licensing Corporation.



## CT-W770R dbx

AAFES CATALOG  
CRC No. 9297722

### Double Auto-Reverse Cassette Deck

- **Double Auto-Reverse Cassette Transports:** One plays, the other records and plays.
- **Dolby HX PRO:** Improves response in high frequencies and expands dynamic range.
- **dbx\*\* Noise Reduction:** Expands dynamic range to 110dB and improves the signal-to-noise ratio to 92dB.
- **Dolby B/C Noise Reduction:** Lowers "hiss," preserves dynamic range.
- **Anti-Resonance Design:** Honeycomb Chassis defeats local resonance and Large Insulators cancel external vibrations.
- **Plentiful Power Supply:** A high-speed active servo regulator controls and assures a stable power supply for accurate reproduction of digital sources.
- **Full-Logic Tape Transports:** Comfortable and jam-free.
- **Relay PLAY:** Plays second tape when first ends.
- **Synchro-Start Dubbing:** At normal or double speed.
- **Auto REC Mute:** Records "cue-blanks" between songs.
- **Music/Skip Search:** Skip up to 15 songs in either direction.
- **Blank Skip/Blank Search:** Skip blank portions or find blank portions for play or recording.
- Auto Tape Selector and Timer Recording/Play (with optional timer)
- MPX Filter Switch
- Headphone Output
- Large Multi-Information FL Display
- SR (System Remote) terminal

\*\* dbx is a trademark of dbx, Inc.



## CT-W500

### Double Cassette Deck

- **Double Cassette Transports:** One plays, the other records and plays.
- **Dolby B/C Noise Reduction:** Lowers "hiss," preserves dynamic range.
- **Anti-Resonance Design:** Honeycomb Chassis defeats local resonance and Large Insulators cancel external vibrations.
- **Plentiful Power Supply:** A high-speed active servo regulator controls and assures a stable power supply for accurate reproduction of digital sources.
- **Full-Logic Tape Transports:** Comfortable and jam-free.
- **Relay PLAY:** Plays second tape when first ends.
- **Repeat Relay Play:** Repeats relay play up to 12 times.
- **Synchro-Start Dubbing:** At normal or double speed.
- **Auto REC Mute:** Records "cue-blanks" between songs.
- **Music/Skip Search:** Skip up to 15 songs in either direction.
- **Blank Skip/Blank Search:** Skip blank portions or find blank portions for play or recording.
- Auto Tape Selector and Timer Recording/Play (with optional timer)
- Headphone Output
- Large Multi-Information FL Display
- SR (System Remote) terminal

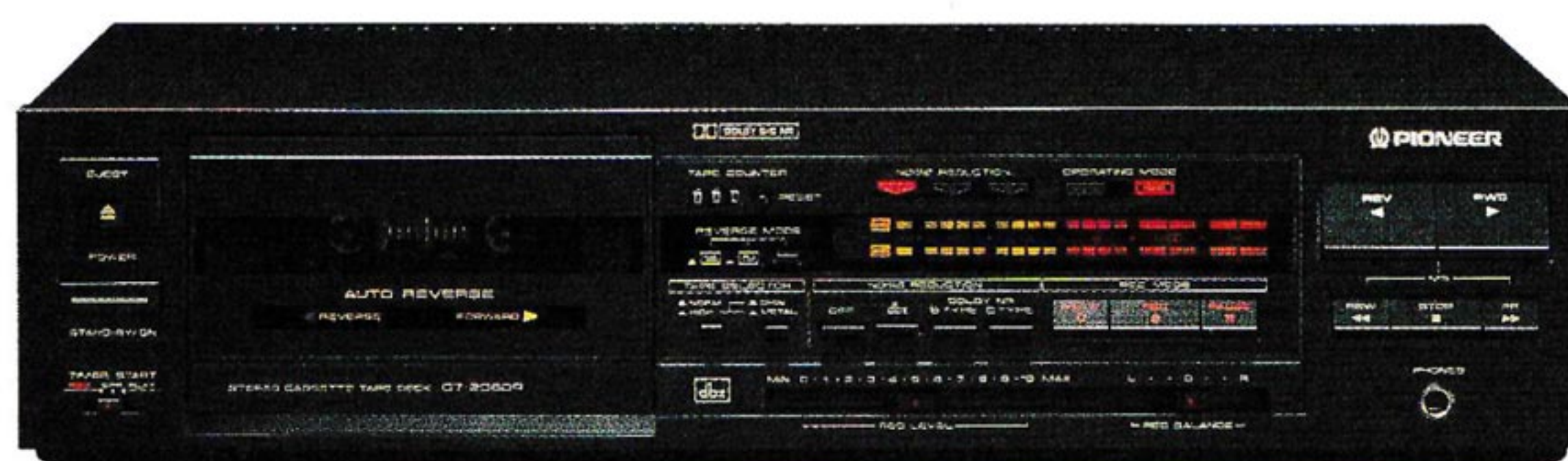

## CT-2080R dbx

AAFES  
CRC No. 9295809

### Quick-Auto-Reverse Cassette Deck

- **Quick-Auto-Reverse Cassette Transport:** Automatic REC/PLAY both sides.
- **Full-Logic Tape Transports:** Comfortable and jam-free.
- **dbx Noise Reduction:** Expands dynamic range to 110dB and improves the signal-to-noise ratio to 92dB.
- **Dolby B/C Noise Reduction**
- **Music Search:** Quickly finds the song you want.
- **One-Touch Recording**
- **Rec Mute:** To add "cue-blanks" between songs.
- LED Level Meters for each channel
- SR (System Remote) terminal

# Turntable



## PL-L70

ATALOG  
CRC No. 9306838

### Programmable Linear-Tracking Turntable

- **Computer-Programmed Automatic Operation:** Programmed Play, Skip Play and Repeat Play made easy with a microprocessor and a precise optical music sensor.
- **Dynamic Resonance Absorber (DRA):** Eliminates resonance-induced vibration in tone arm.
- **Linear Tracking:** Better sound definition because tracking error is reduced.
- **"Flat-Torque" Coreless Quartz-PLL Direct-Drive Motor:** Smooth, stable platter rotation. Pioneer Stable Hanging Rotor\*\*\* reduces spindle wobble.
- Automatic Disc Size/Speed Selector
- Manual Cueing Controls

\*\*\* Stable Hanging Rotor is a trademark of Pioneer Electronic Corporation.

# Speaker Systems



## S-55TS

### 2-Way Bass-Reflex Speaker System with In-Line Vertical Twin Woofers

- **In-Line Vertical Design:** Two woofers and a tweeter are vertically aligned for excellent directivity and stereo imaging, providing a rich, deep "wraparound" sound field.
- **Symmetrical Design:** Reduces mutual interference of soundwaves on vertical axis, thus enhancing bass resolution.
- **Twin 5½" (14cm) Woofers:** Parallel-driven, macromolecular film-laminated diaphragms for smooth and powerful bass reproduction; vertically aligned, the effective speaker diameter is theoretically extended to that of an 8" (20cm) woofer.
- **1" (2.5cm) Dome Tweeter:** The 99%-pure carbon used in the ceramic-carbon diaphragm assures clarity with accurate response.
- **Midship Mounts:** Woofers are midship-mounted to protect sound quality from damage resulting from the generation of unwanted resonance.
- **Speaker Stand:** For improved sound performance.
- **Baffleboard Flocking:** Reduces reflections of high-frequency components and dampens unwanted radiation of sound.
- **Round Cornered Baffle:** Reduces diffraction of sound inside the enclosure.
- **Magnetic Shield:** Prevents magnetic leakage that could otherwise effect color on screen of nearby TV.
- **Power Capability:** 120 watts (max. music power).

### Pioneer Technology Achieves the "Impossible"

One of our two main goals in creating the S-55TS was to achieve bass reproduction equivalent to that of a system many times its size and price. The second was the reproduction of a spatially wider acoustic field with the kind of "wraparound" effect analogous to that of a concert hall.

Sound impossible? Yes, but our engineers tackled the job with enthusiasm. They chose the two-way, bass-reflex approach — long the favorite of audio purists. But they gave it not one but two woofers, each with macromolecular film-laminated diaphragms 5½" (14cm) in diameter and each with a low-loss, low-pass filter in an electrically symmetrical design to discourage mutual interference. Pioneer's exclusive "Midship" mount design puts the woofers not directly on the baffleboard but on the support inside the cabinet to dampen mechanical vibrations. Because of this, the powerful output of the woofers does not compromise the delicate tonal quality in the vital midrange.

The twin-woofer innovation helped achieve goal number one — bigger, truer bass sound. Now then, for goal number two — the "wraparound" effect.

The first step was to array the twin woofers above and below the 1" (2.5cm) dome tweeter which has a ceramic-carbon diaphragm of 99.9% pure carbon and thus is capable of handling even the crashing, pulsing sound of marching-band cymbals with accuracy. The exact vertical symmetry of the three drivers forms a theoretical coaxial configuration in which sound localization is very clear and precise.

The impossible mission was accomplished. To believe it with your own ears, hear the S-55TS in action.

AAFES

CRC No. 9304528

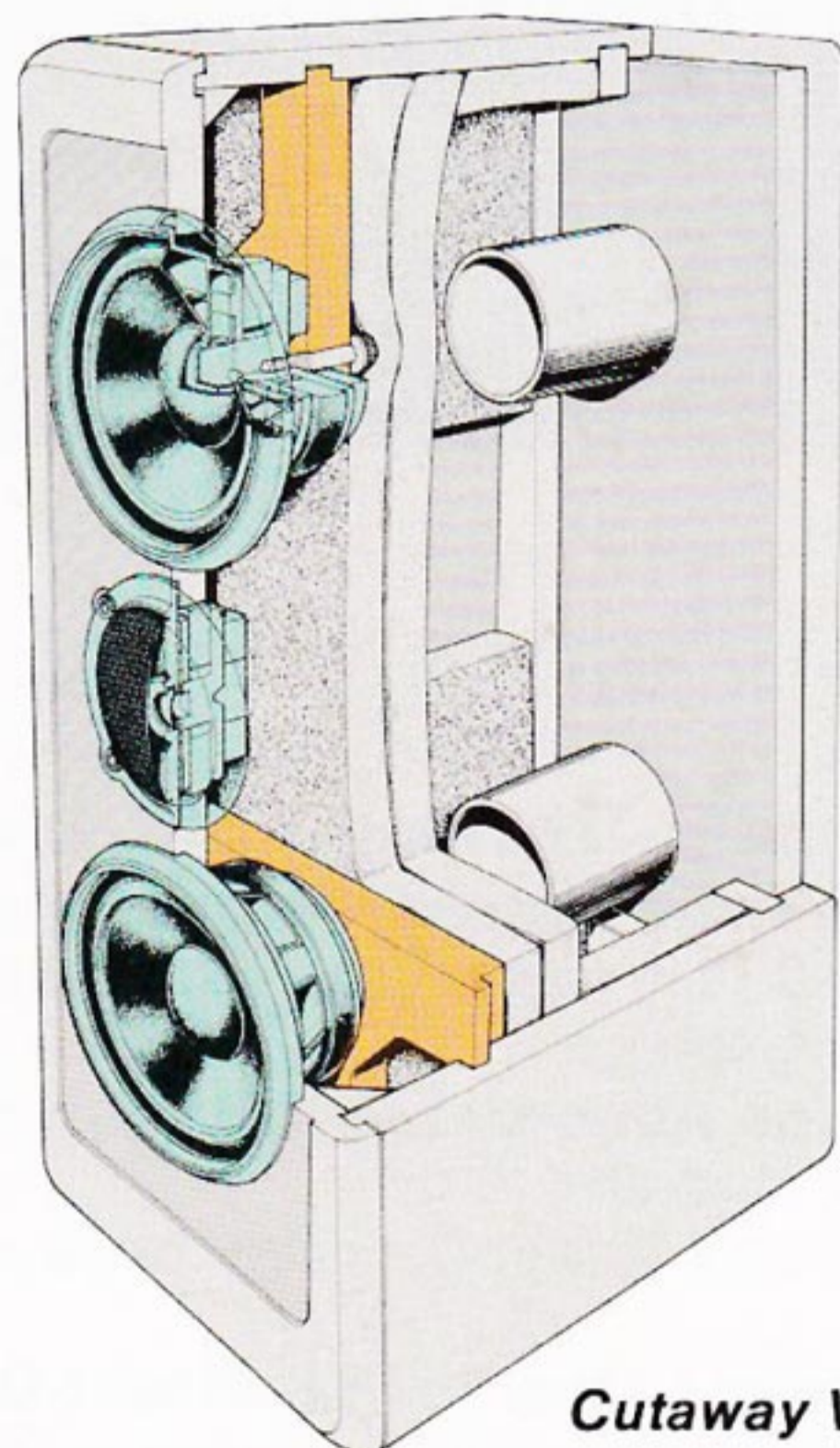

Cutaway View

### In-Line Vertical Design Performance for Coaxial Sound Effects

Data were recorded via a microphone rotated 360 degrees on an axis perpendicular to the baffle. The closer to the outer ring of the graph, the more acoustically "real" the perceived sound field.

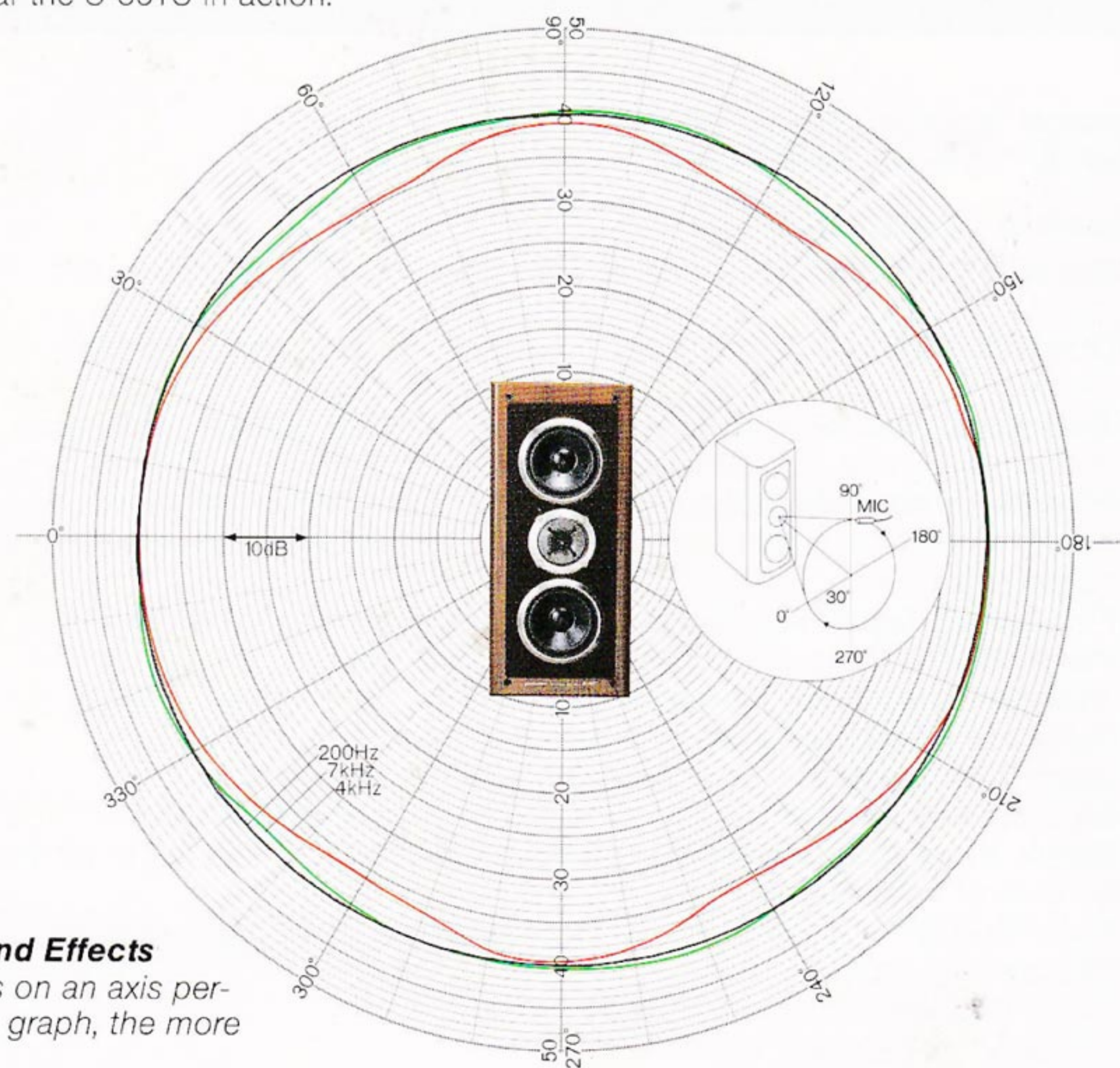



AAFES

CRC No. 9386608



AAFES

CRC No. 9305731

## CS-T7000

### 4-Way Bass-Reflex Speaker System with 12" Woofer

- **Large 12" (30cm) Cone Woofer:** Coupled by resonant air column to large enclosure for rich lows, extended down to 30Hz.
- **4<sup>3</sup>/<sub>4</sub>" (12cm) Cone Midrange:** Delivers smooth mids for natural vocals and other sounds in the mid-frequency range.
- **Horn Tweeter:** Disperses highs evenly throughout your room through its acoustic lens; a self-restoring protection circuit prevents voice-coil burnout.
- **Two 1<sup>5</sup>/<sub>8</sub>" (4.2cm) Cone Supertweeters:** Extend high-frequency response for wide-range and clear sound reproduction.
- **High-Profile Design:** "Tall-boy" size meets height of SYSTEM CD900S and SYSTEM CD700.
- **High Power Capability:** 240 watts (max.) high-power handling capacity.

## CS-T6000

### 4-Way Bass-Reflex Speaker System with 12" Woofer

- **Large 12" (30cm) Cone Woofer:** With rich lows, extended down to 32Hz.
- **4<sup>3</sup>/<sub>4</sub>" (12cm) Cone Midrange:** Delivers smooth mids for natural vocals and other sounds in the mid-frequency range.
- **2<sup>5</sup>/<sub>8</sub>" (6.6cm) Cone Tweeter:** Disperses highs evenly throughout your room through its acoustic lens.
- **Horn Supertweeter:** Extends high-frequency response for wide-range and clear sound reproduction.
- **System Matching Design:** Designed to match the looks and performance of SYSTEM CD900S and SYSTEM CD700.
- **High Power Capability:** 240 watts (max.).



**AAFES CATALOG**  
CRC No. 9347519



**CATALOG**  
CRC No. 9348335

## CS-907

### 4-Way Bass-Reflex Speaker System with 15<sup>3</sup>/<sub>4</sub>" Woofer

- **Extra-Large 15<sup>3</sup>/<sub>4</sub>" (40cm) Woofer with EBD (Electronic Bass Drive):** Efficient reproduction of crisp lows down to 30Hz thanks to heat-resistant voice coil and a large strontium-ferrite magnet.
- **6<sup>1</sup>/<sub>2</sub>" (16cm) Cone Midrange:** Large magnet and high-temperature voice coil "sweeten" vocals and other sounds in the mid-frequency range.
- **Horn Tweeter:** Disperses highs evenly throughout your room through its acoustic lens; a self-restoring protection circuit prevents voice-coil burnout.
- **Four Piezoelectric Supertweeters:** Power and realism are enhanced by extending high-frequency response beyond the audible range.
- **Three Tone Selectors:** Normal, Soft and Crisp
- **13-LED Power Indicators**
- **Wide Frequency Response:** 30Hz – 25,000Hz
- **High Power Capability:** 400 watts (max.)

## CS-607

### 4-Way Bass-Reflex Speaker System with 12" Woofer

- **Large 12" (30cm) Woofer with EBD (Electronic Bass Drive):** Pioneer-exclusive EBD and large, powerful magnet provide crisp and gutsy lows down to 35Hz.
- **4<sup>3</sup>/<sub>4</sub>" (12cm) Cone Midrange:** Large strontium-ferrite magnet for high power and convincing sound.
- **Horn Tweeter:** Disperses highs evenly throughout your room through its acoustic lens; a self-restoring protection circuit prevents voice-coil burnout.
- **Twin Piezoelectric Supertweeters:** Power and realism are enhanced by extending high-frequency response beyond the audible range.
- **11-LED Power Indicators**
- **Wide Frequency Response:** 35Hz – 25,000Hz
- **High Power Capability:** 210 watts (max.)

## S-X7

### Surround-Sound Speaker System

- **Compact and Lightweight (3 lbs. 5 oz./1.5 kg).**
- **Wide Installation Versatility:** Mount on wall or ceiling to suit your listening position and maximize the effect of surround-sound programs.
- **3<sup>1</sup>/<sub>2</sub>" (8.7cm) Full-Range Speaker**
- **Power Capability:** 45 watts (max. music power).



**CATALOG**  
CRC No. 9386731

Enjoy AV Surround with S-X7 Speakers

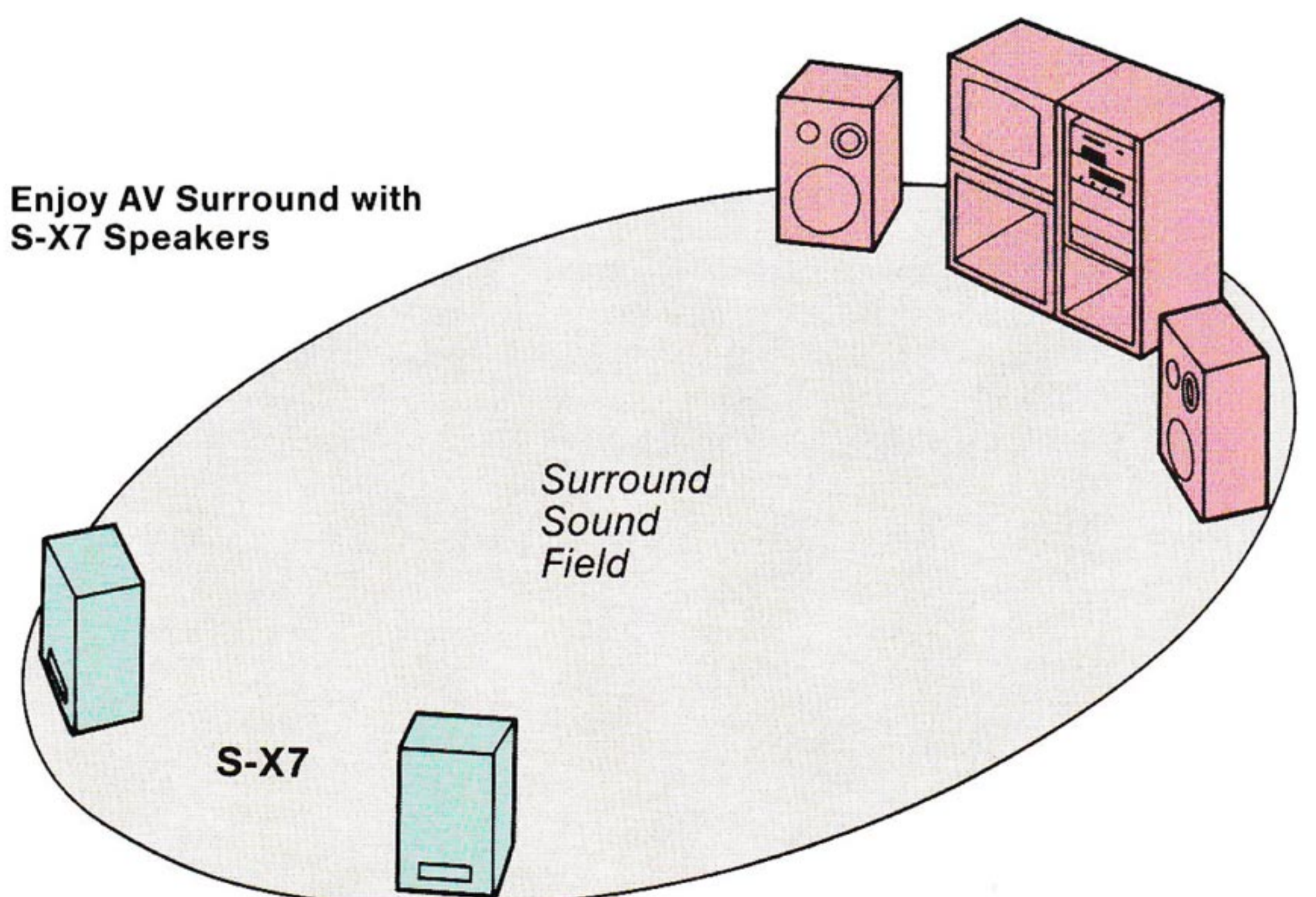

# SYSTEM STEREOS



## *Convenience without Compromise*

*Some of the best hi-fi systems come as "packages" that take the fuss and bother out of selecting and buying individual components one at a time. The systems carrying the famous Pioneer brandname deliver the same high-quality sound and features as our separate components. And have the added advantages of custom cabinets and matching speaker systems — ready to hook up and enjoy!*

## "Smart Remote"™ & Multi-CD



*CS-T7000 4-way bass-reflex speaker system with 12" (30cm) woofer is optional and especially designed to match SYSTEM CD900S and SYSTEM CD700 in size, looks and performance.*

AAFES CATALOG

CRC No. 9299504

## SYSTEM CD900S

### SA-1490S High-Power Amplifier with "Smart Remote"™

- Continuous average power output of 130 watts\* per channel, min., at 8 ohms, from 20Hz to 20,000Hz, with no more than 0.05% total harmonic distortion

- AV SR "Smart Remote"™ ■ L/R-separate 7-band graphic equalizer and spectrum analyzer ■ Motor-driven volume control

### TX-1090Z Quartz-PLL Synthesizer FM/AM Tuner

- 24-random FM/AM station presets; set and recall any combination of 24 FM/AM stations. ■ Auto/manual station search ■ Large AM loop antenna

### CT-W700R Full-Logic, Double Auto-Reverse Cassette Deck

- PLAY (Deck I) and REC/PLAY (Deck II) ■ Continuous Deck I-II auto-reverse relay play ■ Normal/high-speed synchro copy ■ Dolby B/C NR ■ Music/skip search ■ Blank skip/Blank search ■ Auto REC mute

### PL-333 Fully Automatic Turntable

- Low-mass straight tone arm ■ High-performance DC-servo motor with Stable-Hanging Rotor™ ■ Universal-type cartridge

### PD-M400 Multi-Play Compact Disc Player

- "6-Pack" magazine for 6-disc continuous play ■ Programmable for up to 32 selections ■ Random Play: Onboard microprocessor chooses playing order for all loaded discs at random, without playing tracks twice.+ ■ 4-way repeat ■ 2-speed manual and track search
- Digital filter and twin D/A converters ■ Anti-resonance design

### CB-F900 Audio Cabinet

- Simulated walnut-grain finish ■ Casters ■ Glass door

\* Measured pursuant to the Federal Trade Commission's Trade Regulation Rule on Power Output Claims for Amplifiers.

+ Some tracks may repeat when a disc contains more than 64 tracks.



## Double Cassette & Multi-CD



*CS-T6000 4-way bass-reflex speaker system with 12" (30cm) woofer is optional and especially designed to match the looks and performance of SYSTEM CD900S and SYSTEM CD700.*

AAFES CATALOG  
CRC No. 9299538

## SYSTEM CD700

**RX-510 Double Cassette Deck/Amplifier/Synthesizer FM/AM Tuner with Remote**

**Amplifier:** ■ Continuous average power output of 110 watts\* per channel, min., at 8 ohms, from 20Hz to 20,000Hz, with no more than 0.09% total harmonic distortion

■ Pioneer AV SR remote control ■ 5-band graphic equalizer with spectrum analyzer ■ Motor-driven volume control ■ Mic mixing

**Tuner:** ■ 24-random FM/AM station presets; set and recall any combination of 24 FM/AM stations ■ Auto/manual tuning

**Cassette Deck:** ■ Double cassette transports ■ Normal/high-speed synchro copy ■ Deck I-II continuous relay play ■ Dolby B NR ■ Auto tape selector

**PL-310Z Fully Automatic Turntable**

■ Low-mass straight tone arm ■ High-performance DC-servo motor with Stable-Hanging Rotor™

**PD-M400 Multi-Play Compact Disc Player**

■ "6-Pack" magazine for 6-disc continuous play ■ Programmable for up to 32 selections ■ Random Play: Onboard microprocessor chooses playing order for all loaded discs at random, without playing tracks twice.+ ■ 4-way repeat ■ 2-speed manual and track search ■ Digital filter and twin D/A converters ■ Anti-resonance design

**CB-F900 Audio Cabinet**

■ Simulated walnut-grain finish ■ Casters ■ Glass door

## Double Cassette & 3-Way Speaker Systems



AAFES CATALOG  
CRC No. 9301201

## SYSTEM E2525

**RX-310 Double Cassette Deck/Amplifier/Synthesizer FM/AM Tuner with Remote**

**Amplifier:** ■ Continuous average power output of 36 watts\* per channel, min., at 8 ohms, from 20Hz to 20,000Hz, with no more than 0.09% total harmonic distortion

■ Pioneer SR remote control ■ 5-band graphic equalizer ■ Electronic volume control ■ Mic mixing

**Tuner:** ■ 24-random FM/AM station presets; set and recall any combination of 24 FM/AM stations.

**Cassette Deck:** ■ Double cassette transports ■ Synchro start for dubbing ■ Deck I-II continuous relay play ■ Dolby B NR ■ Auto tape selector

**PL-210Z Auto-Return Turntable**

■ Low-mass straight tone arm ■ High-performance DC-servo motor with Stable-Hanging Rotor™

**CS-579 3-Way Bass-Reflex Speaker System**

■ 7<sup>7</sup>/<sub>8</sub>" (20cm) cone woofer ■ 60 watts maximum music power

**CB-F130 Audio Cabinet**

■ Simulated walnut-grain finish ■ Casters ■ Glass door

\* Measured pursuant to the Federal Trade Commission's Trade Regulation Rule on Power Output Claims for Amplifiers.

+ Some tracks may repeat when a disc contains more than 64 tracks.

## Double Cassette, CD & 3-Way Speaker Systems



## Midi-Sized System with Multi-CD Player



CATALOG

CRC No. 9303611

### SYSTEM CD360

#### RX-Z71 Double Cassette Deck/Amplifier/Synthesizer FM/AM Tuner with Remote

**Amplifier:** ■ Continuous average power output of 27 watts\* per channel, min., at 8 ohms, from 40Hz to 20,000Hz, with no more than 0.3% total harmonic distortion

■ L/R-independent 5-band graphic equalizer ■ Surround-sound circuitry ■ 5 inputs ■ Electronic volume ■ Mic mixing ■ Volume level LED indicators ■ Multi-program timer ■ Remote control

**Cassette Deck:** ■ Double deck with auto-reverse PLAY on Deck II ■ Dolby B NR ■ Normal/high-speed copy ■ Deck I-II relay play ■ CD synchro REC start ■ Automatic tape selector

**Tuner:** ■ Quartz-PLL FM/AM synthesizer tuner ■ FM stereo/mono switch

#### PL-Z81 Automatic Turntable

■ Low-mass straight pipe tone arm ■ Convenient front operation

#### PD-Z71 Compact Disc Player

■ Twin D/A converters for L/R channels ■ Digital filter ■ Random play ■ 20-track random-access programming ■ Pause program ■ Timer start ■ Track/manual search ■ All/programmed track repeat ■ CD-to-cassette tape synchro recording ■ Plays standard 5" (12cm) CDs and new mini-format 3" (8cm) CD singles

#### CS-579 3-Way Bass-Reflex Speaker System

■ 7 $\frac{1}{8}$ " (20cm) cone woofer ■ 60 watts maximum music power

#### CB-Z71 Audio Cabinet

■ Specially designed for Midi System Stereo ■ Simulated walnut-grain finish ■ Casters ■ Glass door

\* Measured pursuant to the Federal Trade Commission's Trade Regulation Rule on Power Output Claims for Amplifiers.

### Z-70M

#### DC-Z81 Full-Logic Double Auto-Reverse Cassette Deck/Amplifier with Remote

**Amplifier:** ■ Continuous average power output of 36 watts\* per channel, min., at 8 ohms, from 40Hz to 20,000Hz, with no more than 0.3% total harmonic distortion

■ L/R-independent 5-band graphic equalizer ■ Surround-sound circuitry ■ Motor-driven volume control ■ CD direct input ■ Mic mixing ■ Multi-information FL display ■ Multi-program timer ■ Remote control

**Cassette Deck:** ■ Full-logic control ■ Double auto-reverse deck with REC/PLAY on Deck 1 and PLAY on Deck II ■ Dolby B NR ■ Music Search ■ Deck I-II relay play ■ CD Fade-Edit synchro REC ■ Normal/high-speed copy ■ Automatic tape selector

#### F-Z91 Quartz-PLL Synthesizer FM/AM Tuner

■ Quartz-PLL FM/AM synthesizer tuner ■ 24-random FM/AM station presets; set and recall any combination of 24 FM/AM stations ■ FM stereo/mono switch

#### PL-Z81 Automatic Turntable

■ Low-mass straight pipe tone arm ■ Convenient front operation

#### PD-Z81M Multi-Play Compact Disc Player

■ "6-Pack" magazine for programmable 6-disc play of up to 32 selections ■ Twin D/A converters ■ Honeycomb Chassis ■ Digital filter ■ Programmable pause ■ Random play ■ 3-mode search (disc, track, manual) ■ 3-mode repeat (all discs, single disc, programmable tracks) ■ CD-to-cassette tape synchro REC

#### S-Z81D Magnetically Shielded, Bass-Reflex 3-Way Speaker System

■ Ideal for digital sound ■ 9 $\frac{1}{16}$ " (23cm) cone woofer with elastic composite diaphragm developed for powerful, crisp bass ■ 2 $\frac{5}{8}$ " (6.6cm) cone tweeter and 1 $\frac{1}{16}$ " (1.8cm) dome supertweeter

# VIDEO COMPONENTS



## *Here's Looking at You*

*Some people think a TV picture should be picture-postcard perfect, with razor-sharp focus and in brighter-than-life color. Others (and we are among them) think the picture (and the sound) should accurately reflect whatever source is input to it. This is the hi-fi approach for the eyes, and it's yours to enjoy in every LD player and monitor in this catalog, thanks to original Pioneer technology. Here's looking at you!*

# LD Players



AAFES CATALOG  
CRC No. 9363235

## CLD-3030 NTSC

### CD/CDV/LD Player with Digital Memory

- **Triple-Play Talents:** Play 12" or 8" LaserVision discs of CAV or CLV types, new CDV, or any CD, including the new 3-inch type.
- **High-Quality Picture:** High 425-line horizontal resolution, 46dB S/N low video noise and a noiseless picture scan, even on CLV discs.
- **High-Quality Digital Sound:** With 4X oversampling digital filter, it gives a wide frequency response of 4 – 20,000Hz, a wide dynamic range of 95dB and an ultralow noise and distortion of 107dB S/N and 0.0035% T.H.D.
- **Twin D/A Converters:** Reduce phase differences for a deep, bright sound with sharp image localization.
- **8-Bit Sampling RAM Chip with One Megabit Memory:** "Trick plays" with ongoing sound and clean picture; Conveniences include Still with Sound, Strobe Motion, One-Shot Memory, Digital Effects, etc.
- **Compact OEIC (Optoelectronic IC) Pickup:** For clean picture.
- **One-Chip Video IC:** For smaller size, less power consumption and higher reliability.
- **Constant-Distance Tilt Servo:** For accurate tracking.

- **Optical Digital Output:** A terminal is provided for use with an optional optical-fiber lead to transfer data to a digital amp or outboard D/A converter.
- **Jog & Shuttle Play:** Via remote control or front panel.
- **CD Auto Program Edit:** Lets you know how many tracks on a given CD can be recorded on one side of a given tape.
- Program Play for 20 Chapters or Tracks
- CD Random Play (of all or programmed tracks)
- 5-Mode Repeat: 2-point, chapter, one-side, memory, program
- 10-Key Direct Chapter/Track Search and Play
- Frame Number Search with CAV LDs
- Track and Time Search for CD/CDVs
- In/Out terminal for SR remote control
- Improved front-panel operation/display with "Contents Calendar" for LD, CD and CDV
- Large Remote Control with Jog & Shuttle, 10 keys, etc.

### More About the CLD-3030

#### Play Any Laser-Read Program

You know the advantages the laser beam brings to LaserVision and Compact Discs — they don't wear out, they contain nearly perfect pictures and digital sound, and they are very easy to play. The Pioneer CLD-3030 takes maximum advantage of all these benefits in audio-only CDs (including the new 3-inch CD singles), CDVs with video content and, of course, medium and full-sized LD videodiscs. The CLD-1030 and LD-850 also feature wide versatility in disc selection and playback.

#### High-Quality Picture

Using high-tech miniaturization techniques, the new laser pickup used in all three of these products has been reduced to half the size of conventional pickups. It features an Optoelectronic IC (OEIC) chip with both a pin-photodiode to convert optical signals to radio frequencies and a wide-band RF amplifier to which they are routed. Because the signal paths are as short and well-shielded as possible, outside interference is less of a threat to picture quality. Another tiny chip for the video

circuitry saves space by packing several complicated circuits into one IC: fewer parts, smaller size, less power consumption and higher reliability are the benefits.

#### Constant-Distance Tilt Servo

This is a standard feature on Pioneer LD players. It automatically compensates for any excessive warps in any disc to assure accurate tracking — adding up to impressive improvements in both sight and sound.

#### High-Quality Sound

Passing on the incredible fidelity of audio content of digitized LDs and CDs to your ears without compromise was the goal of the design of the audio section of the Pioneer CLD-3030. One of major contributions is the use of state-of-the-art "4X oversampling" to extend the usual 44.1kHz digital sampling frequency to 176.4kHz. The benefits of this are explained in the previous section on CD players, as are those of the Twin D/A converters and other aspects of the digital-audio section of the CLD-3030.

#### Optical Digital Output & Anti-Resonance Measures

A terminal is provided on the CLD-3030 for use with an optional optical-fiber lead to transfer data to a digital amp or outboard D/A converter. Also, as in our newest and finest high-fidelity amps, preamps, CD players and receivers, a number of Anti-Resonance measures are taken in the CLD-3030, CLD-1030 and LD-850D to preserve sound quality and live up to the reputation Pioneer has earned over its fifty years in high fidelity.

#### Full Auto Disc Selection

A single, high-performance brushless motor drives the disc you choose to play on any of these new players. When the tray opens fully, you load the disc, press PLAY on the front panel or the remote control and it's all automatic from then on. The tray closes, the disc size and type is detected and play begins.



**CLD-1030** SR COMPACT DISC DIGITAL AUDIO LaserDisc™ CD VIDEO NTSC

**CD/CDV/LD Player with Color-Lock Scan**

- **Triple-Play Talents:** Play 12" or 8" LaserVision discs of CAV or CLV types, new CDV, or any CD, including the new 3-inch type.
- **High-Quality Picture:** High 425-line horizontal resolution, 46dB S/N low video noise and a Color-Lock Scan on CAV/CLV discs.
- **High-Quality Digital Sound:** With 2X oversampling digital filter, it gives a wide frequency response of 4 – 20,000Hz, a wide dynamic range of 95dB and a very low noise and distortion of 98dB S/N and 0.005% T.H.D.
- **Compact OEIC (Optoelectronic IC) Pickup, One-Chip Video IC and Constant-Distance Tilt Servo:** For clean picture and sound, smaller size, less power consumption, higher reliability and for accurate tracking.

- **CD Auto Program Edit:** Lets you know how many tracks on a given CD can be recorded on one side of a given tape.
- Program Play for 20 Chapters or Tracks
- CD Random Play (of all or programmed tracks)
- 5-Mode Repeat: 2-point, chapter, one-side, memory, program
- 10-Key Direct Chapter/Track Search and Play
- Frame Number Search with CAV LDs and Time-Number Search with CLV LDs
- Track and Time Search for CD/CDVs
- In/Out terminal for SR remote control
- Improved front-panel operation/display
- Full-function Remote Control with 10 keys, etc.

**Digital Memory for Special Picture Effects**

The CLD-3030 contains a RAM (Random-Access Memory) chip using 8-bit sampling (256-level). It has a memory capacity of one megabit, and its reference-shift TBC servo system enables various "trick plays" — all with a clear, stable picture from CAV and CLV discs. It also makes possible STILL with SOUND for a single, "frozen" frame with ongoing audio; your choice of normal or digitally processed display via DIGITAL MEMORY; exciting STROBE MOTION in seven steps (1/1, 1/2, 1/4, 1/8, 1/16, Step 1 and 3) with ongoing sound; ONE-SHOT MEMORY to display a single frame from one side of one disc for display while you listen to ongoing sound from that or any other disc; and DIGITAL EFFECTS, offering a screenful of divided mosaic patterns made up of after-images of the moving picture while the hi-fi sound plays on.

**Jog & Shuttle for a Professional Touch**

An 8-bit chip backs up this useful feature on the CLD-3030. Use the SHUTTLE ring to adjust scan speeds in either direction. SHUTTLE operations are 2x, 5x, LOW SCAN (approx. 10x) and HIGH SCAN (approx. 30x or 40x). Then, the JOG dial lets you change disc speed for STILL/STEP or SCAN display with a fingertip. Operation in STILL/STEP and 1/2x, 1x and 2x speeds are not accompanied by sound.



Large, Easy-to-Use Jog & Shuttle Dial

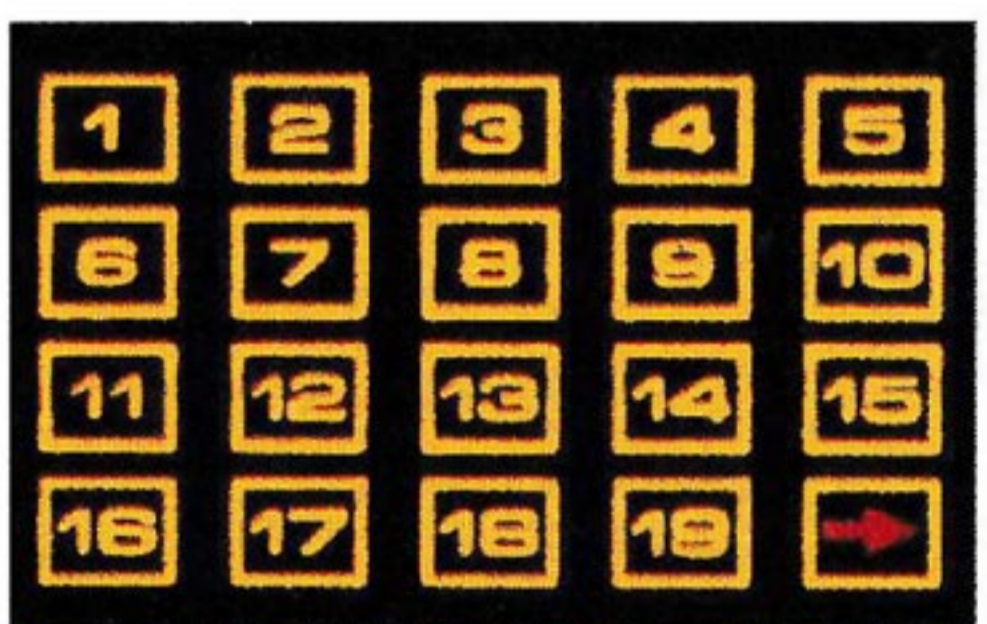

**Contents Calendar:** Shows which chapter is being played or how many chapters are included in the discs and which one is being played (discs with "table-of-contents" codes); it also shows all the chapters you have programmed in the Program Play mode.

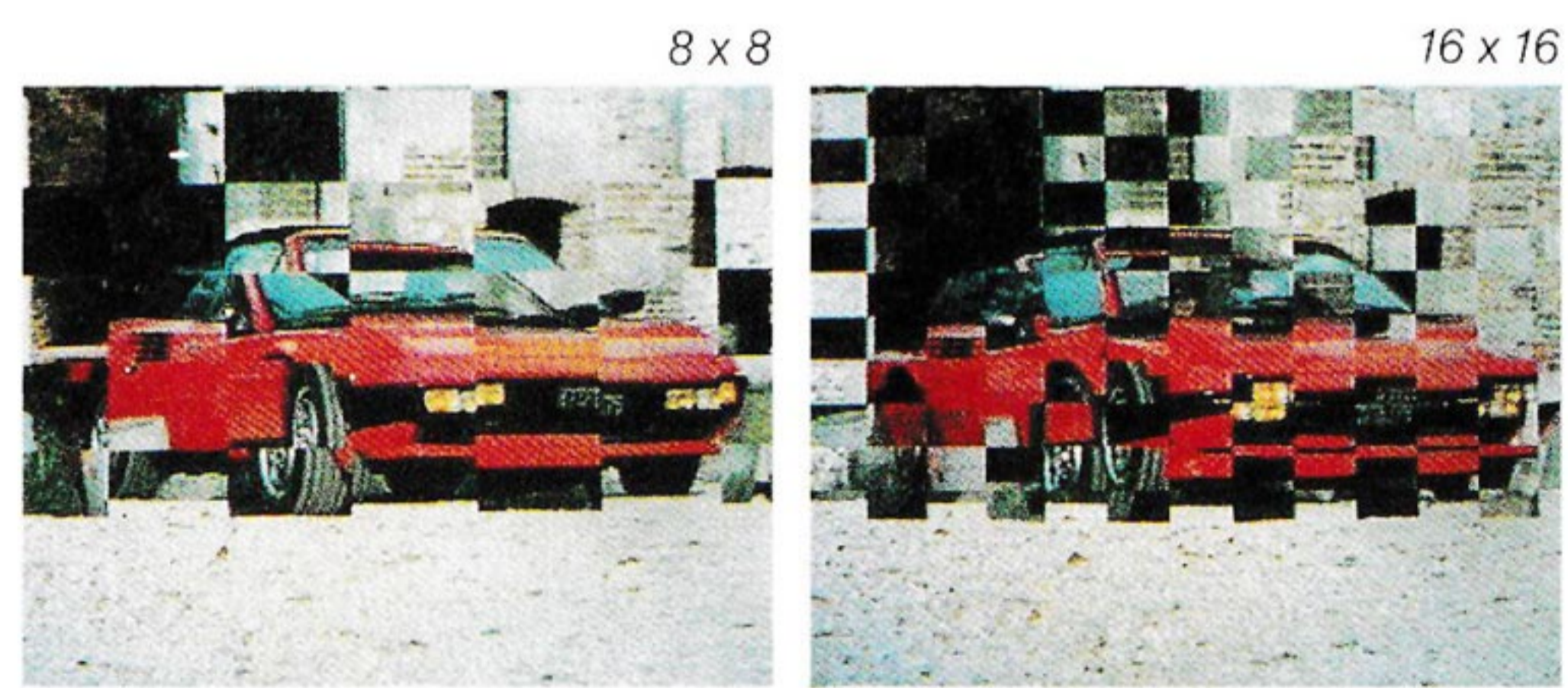

**DIGITAL EFFECTS**  
It offers a screenful of divided mosaic patterns made up of after-images of the moving picture while the hi-fi sound plays on. Perfect for BGV!



STROBE MOTION

Strobe Motion



AAFES CATALOG CRC No. 9363110

## LD-850D NTSC

### LD Player with Digital Sound

- **High-Quality Picture:** High 425-line horizontal resolution, 46dB S/N low video noise and a Color-Lock Scan on CAV/CLV discs.
- **High-Quality Digital Sound:** With 2X oversampling digital filter, it gives a wide frequency response of 4 – 20,000Hz, a wide dynamic range of 95dB and a very low noise and distortion of 98dB S/N and 0.005% T.H.D.
- **Compact OEIC (Optoelectronic IC) Pickup, One-Chip Video IC and Constant-Distance Tilt Servo:** For clean picture and sound, smaller size, less power consumption, higher reliability and for accurate tracking.

- Program Play for 20 Chapters or Tracks
- 5-Mode Repeat: 2-point, chapter, one-side, memory, program
- 10-Key Direct Chapter/Track Search and Play
- Frame Number Search with CAV LDs and Time Number Search with CLV LDs
- In/Out terminal for SR remote control
- Improved front-panel operation/display
- Full-function Remote Control with 10 keys, etc.

**LaserDisc**™ LaserDisc is a trademark of Pioneer Electronic Corporation.  
 The LaserVision mark certifies compatibility with other laser optical video products bearing the mark.

### Feature Comparison

	CLD-3030				CLD-1030				LD-850D	
	LD		Compact Disc		LD		Compact Disc		LD	
	Standard-Play (CAV)	Extended-Play (CLV)	CD	CDV	Standard-Play (CAV)	Extended-Play (CLV)	CD	CDV	Standard-Play (CAV)	Extended-Play (CLV)
<b>General functions</b>										
TV/LDP selector	○	○	○	○	○	○	○	○	○	○
Play	○	○	○	○	○	○	○	○	○	○
Eject	○	○	○	○	○	○	○	○	○	○
Pause	○	○	○	○	○	○	○	○	○	○
<b>Audio functions</b>										
Audio monitor (Stereo, 1/L, 2/R)	○	○	○	○	○	○	○	○	○	○
Auto digital/analog	○ <sup>1</sup>	○ <sup>1</sup>			○ <sup>1</sup>	○ <sup>1</sup>			○ <sup>1</sup>	○ <sup>1</sup>
CX system on/off	○ <sup>2</sup>	○ <sup>2</sup>			○ <sup>2</sup>	○ <sup>2</sup>			○ <sup>2</sup>	○ <sup>2</sup>
<b>Scan/search functions</b>										
Jog & shuttle	○	○	○	○	○	○	○	○	○	○
Scan (forward/reverse)	○	○	○	○	○	○	○	○	○	○
Chapter-number search	○ <sup>3</sup>	○ <sup>3</sup>			○ <sup>3</sup>	○ <sup>3</sup>			○ <sup>3</sup>	○ <sup>3</sup>
Track-number search			○	○			○	○		
Chapter skip search (forward/reverse)	○ <sup>3</sup>	○ <sup>3</sup>		○ <sup>4</sup>	○ <sup>3</sup>	○ <sup>3</sup>			○ <sup>3</sup>	○ <sup>3</sup>
Track search			○	○			○	○		
Frame-number search	○				○				○	
Time-number search		○	○	○		○	○	○		○
<b>Repeat play functions</b>										
2-point repeat	○	○	○	○	○	○	○	○	○	○
Memory repeat	○	○	○	○	○	○	○	○	○	○
Chapter repeat	○ <sup>3</sup>	○ <sup>3</sup>			○ <sup>3</sup>	○ <sup>3</sup>			○ <sup>3</sup>	○ <sup>3</sup>
Track repeat			○	○			○	○		
Programmed-chapter repeat	○ <sup>3</sup>	○ <sup>3</sup>			○ <sup>3</sup>	○ <sup>3</sup>			○ <sup>3</sup>	○ <sup>3</sup>
Programmed-track repeat			○	○			○	○		
One-side repeat	○	○	○	○	○	○	○	○	○	○
<b>Special play functions</b>										
Multispeed play (forward/reverse, 9 steps)	○	○		○ <sup>4</sup>	○				○	
Chapter program play (up to 20 chapters)	○ <sup>3</sup>	○ <sup>3</sup>			○ <sup>3</sup>	○ <sup>3</sup>			○ <sup>3</sup>	○ <sup>3</sup>
Track program play (up to 20 tracks)			○	○			○	○		
Program correction	○ <sup>3</sup>	○ <sup>3</sup>	○	○	○ <sup>3</sup>	○ <sup>3</sup>	○	○	○ <sup>3</sup>	○ <sup>3</sup>
Still/step play (forward/reverse)	○	○		○ <sup>4</sup>	○				○	○ <sup>3</sup>
Still with sound	○	○		○ <sup>4</sup>						
Digital effects	○	○		○ <sup>4</sup>						
Stroboscopic motion	○	○		○ <sup>4</sup>						
One-shot memory	○	○		○ <sup>4</sup>						
Random play			○	○ <sup>5</sup>			○	○ <sup>5</sup>		
Auto program edit			○	○ <sup>5</sup>			○	○ <sup>5</sup>		

**Notes:**

- 1) Applicable only with discs having digital sound. 2) Applicable only with discs having CX noise reduction codes. 3) Applicable only with discs having chapter number codes. 4) Applicable only with video-part tracks on CDVs. 5) Applicable only with audio-part tracks on CDVs. □ CX is a trademark of CBS Inc.

# Monitor/Receivers



AAFES-PACIFIC CRC No. 9308826

## SD-P4002 NTSC

### High-Fidelity Projection Monitor Receiver

- **620-Line Horizontal Resolution:** For high-quality picture reproduction on the huge (40"/101cm diag.) screen with a wide view angle of horizontal 120 and vertical 50 degrees.
- **400 Ft-L High-Luminance Bright Picture:** Highest-ever luminance for Pioneer projection. Our new lens design makes maximum use of available light, while our new Dynamic Focus CRT system and one-time reflection design in projection path mean you don't have to dim your room lights to enjoy a crisp, full-color picture.
- **New Border Correction Circuit:** Reproduces sharp image outlines and details even in a large-size screen, extending video frequency range to a wide 10MHz.
- **High-Resolution CRT:** Focus performance is improved with edge-to-edge clear picture, thanks to a Dynamic Focus design.
- **High-Voltage Stabilizer Circuit and 6000pF High-Voltage Capacitor:** Plentiful, stable power for CRTs helps eliminate image distortion, brighten picture.
- **Linear Deflection Circuit:** Suppresses image distortion.
- **Black-to-White Tone Transition:** Dynamic Black Level Compensation Circuit reproduces solid black, improving depth and contrast, while Dynamic Gamma Compensation Circuit prevents blooming and loss of white portion to expand dynamic range of luminance performance.
- **Improved Color:** Quality of color rendition is superb thanks to a Comb Filter, a Dynamic Color Processor Circuit, an Automatic Color-Temperature Control Circuit and a CNR (Color Noise Reduction) Circuit.
- **Pioneer-Exclusive DPO System:** Dynamic Picture Optimizer (DPO) for picture quality control (color, contrast, brightness) to best suit for the brightness of viewing environment. Two modes: STD and DPO ADJUST with "Last Memory" function.
- **Black-Stripe, Double-Sided Lenticular Screen:** Suppresses annoying external-light reflection and reduces color shift.
- **Liquid-Cooled Coupling Design:** Realizes a high-contrast bright picture by eliminating internal reflection. It also strongly resists external magnetic-flux interference (as from speakers, etc.).
- **High-Resolution synthesizer Tuner and MTS:** For high-quality reception, with a wide-range SAW filter and PLL synthesizer. MTS (Multichannel TV Sound) decoder is built in.
- **Built-In Amplifier and Speakers:** 13W + 13W amplifier and 6 $\frac{5}{16}$ " (16cm) full-range speakers deliver a hi-fi stereo sound.
- **AV Memory System:** Stores your adjustments for audio (treble, bass) and picture (contrast, color, tint, brightness, sharpness) for instant recall. (3 modes: STD, AV MEMORY-1, AV MEMORY-2.)
- **Full-Function SR System Remote Control:** Controls key operations of the unit itself and a connected LD player.
- **AV Inputs:** 1 on front, 3 on rear. Also, 2 antenna inputs.
- **S Input:** For S-VHS and ED-Beta.
- **Outputs:** AV output, TV out, variable audio out, speaker out.
- On-Screen Operation Status Display
- 23 $\frac{1}{2}$ " (59.7cm) Slim Design

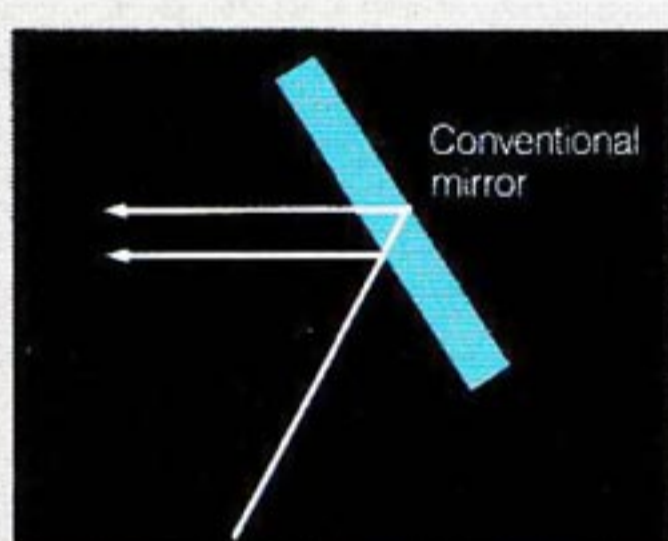
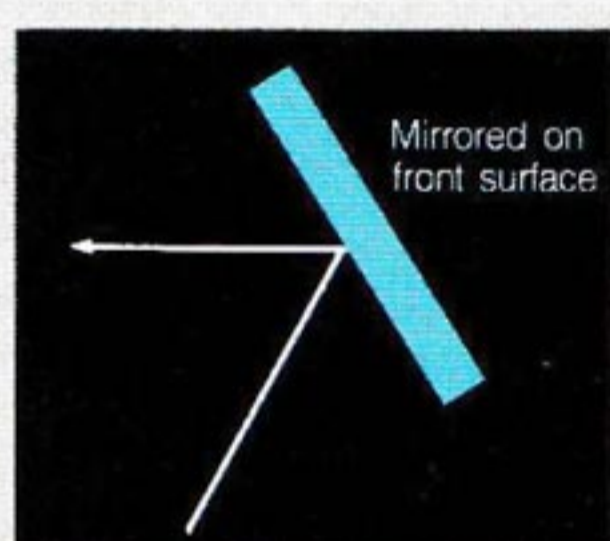

Reflecting from the front surface prevents blurring caused by doubled images.

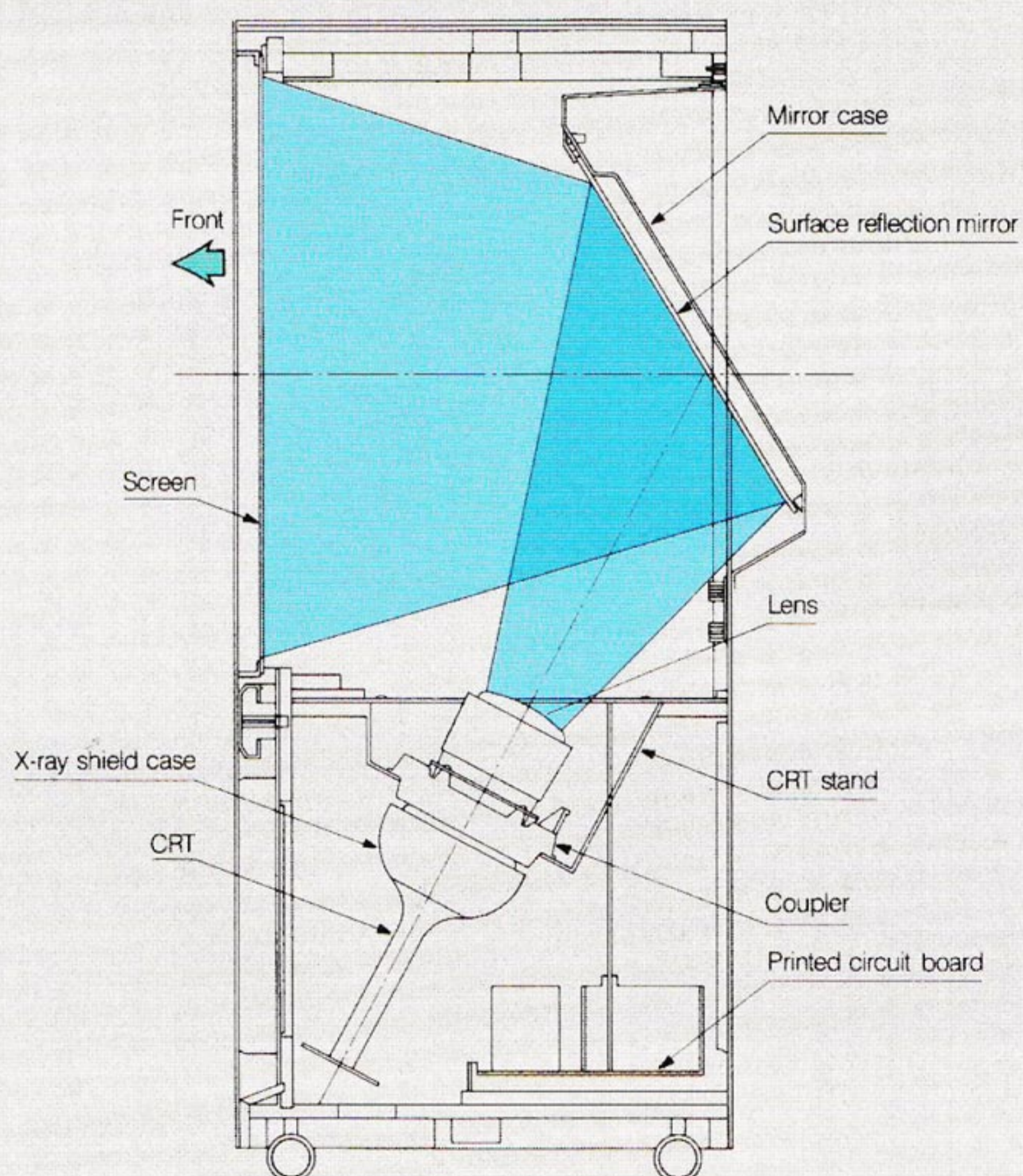

Control Panel



S-Terminal for S-VHS and ED-Beta

Note: TV picture simulated.

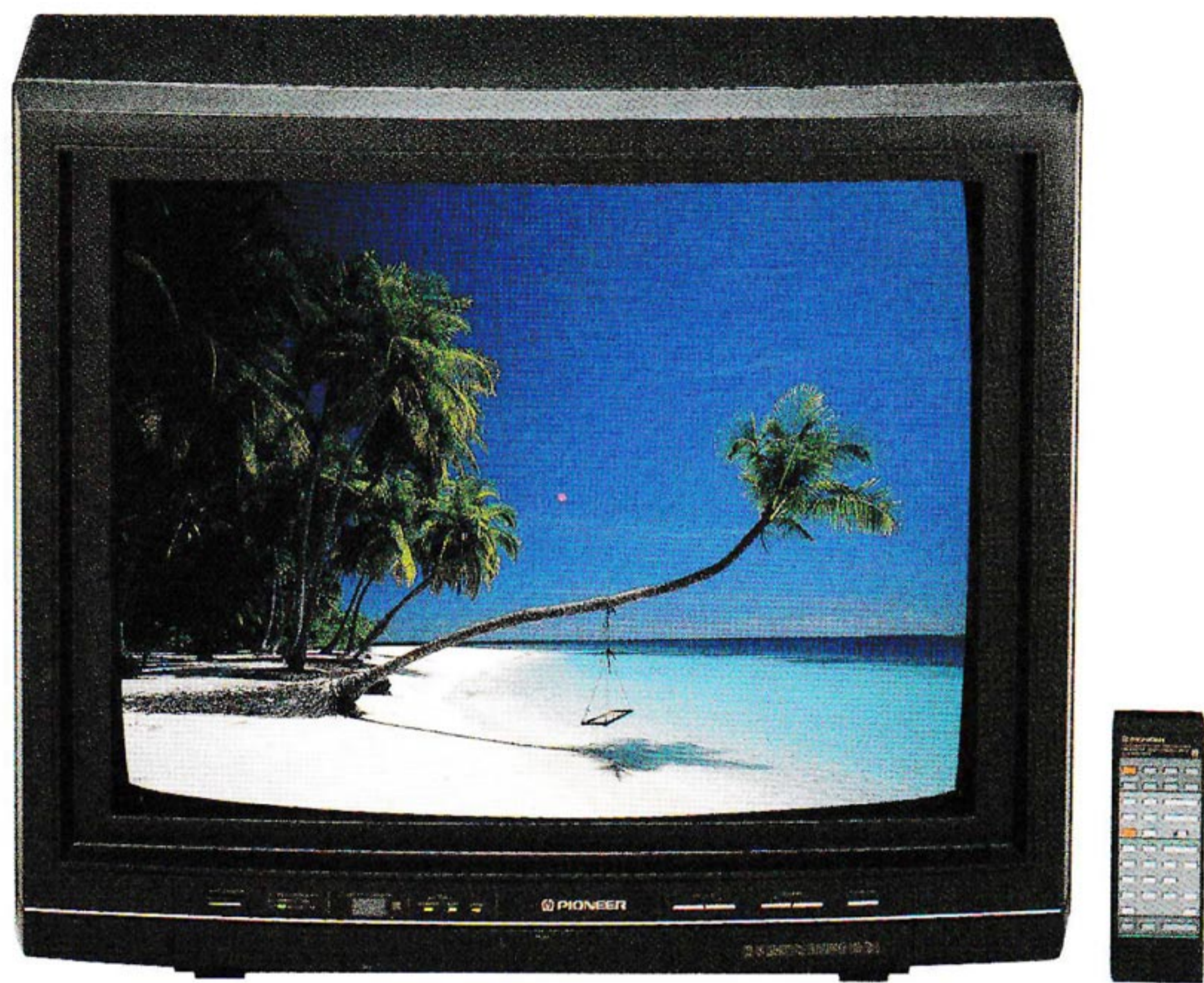

**AAFES-PACIFIC**  
CRC No. 9131814

## SD-281 NTSC

### High-Fidelity Monitor/Receiver

- **Square-Cornered Screen:** 28" diag. CRT shows more picture (26" visual size)
- **600-Line Horizontal Resolution:** Extremely high resolution thanks to 8MHz frequency response and Comb Filter.
- **High-Gain Border Compensation Circuit:** Incorporates a 6-dB gain amp to deliver sharper images and detailed textures; separate Speed Modulation Circuit preserves image-edge contrast.
- **Dynamic Black-Level Compensation Circuit:** Active circuit checks and adjusts density of black areas to prevent loss of line detail in less-dark portions.
- **CNR (Color Noise Reduction) Circuit**
- **Automatic Color-Temperature Control Circuit**
- **Peak ACL (Automatic Contrast Limiter) Circuit:** Prevents "blooming" and reproduces sharp and clear whites.
- **125-Channel Cable TV-Capable Tuner:** With MTS decoder for stereo/SAP reception.
- **Two AV Memory Presets:** Stores your adjustments for audio (treble, bass) and picture (contrast, color, tint, brightness, sharpness) for instant recall. STD button recalls factory-standard settings.
- **11W + 11W Stereo Amplifier:** Drives a pair of detachable speakers.
- Wireless SR Remote Control
- 3 AV Inputs, 1 AV Rec Out and 1 Audio Out (variable)
- 2 RF Antenna Terminals Common for VHF/UHF
- S Input for S-VHS and ED-Beta
- Sleep Timer (30, 60, 90 min.) and On-Screen Function Display



S-Terminal for S-VHS and ED-Beta



**AAFES-EUROPE**  
CRC No. 9308834

## SD-T29 NTSC/PAL/SECAM

### "Trident System" High-Fidelity Monitor/Receiver

- **Trident PAL/SECAM/NTSC Reception:** Fully automatic switching in SECAM (B/G, I, D/K), PAL (B/G, I, D/K) and NTSC (3.58, 4.43) for broadcast/cable TV reception virtually anywhere in the world.
- **Square-Cornered Screen:** 29" diag. CRT shows more picture (27" visual size); aspheric tinted screen defeats annoying external light.
- **600-Line Horizontal Resolution:** Very high resolution thanks to a wide 8MHz frequency response and Comb Filter (NTSC).
- **Dynamic Black-Level Compensation Circuit:** Active circuit checks and adjusts density of black areas to prevent loss of line detail in less-dark portions.
- **Linear Deflection Circuit:** Suppresses vertical image distortion.
- **White Balance Control:** Adjusts white balance for delicate picture quality.
- **PLL Synthesizer Tuner and MTS:** PLL full-synch detector delivers hi-fi picture and sound; VHF, UHF and CATV (NTSC/96 ch.) reception. MTS decoder and stereo/SAP reception (NTSC).
- **10W + 10W Amplifier:** Drives a pair of detachable speakers.
- **Picture Memory Presets:** Stores two sets of your adjustments for picture [contrast, color, tint (NTSC only), brightness, sharpness] for instant recall.
- Full-function SR Remote Control with LD control
- 2 AV Inputs (LD player/VCR) and 1 AV Output
- S Input for S-VHS and ED-Beta
- 1 RF Antenna Terminal and 1 TV Monitor Out
- Headphone Output and Sleep Timer (30, 60, 90 min.)
- On-Screen Function Display



S-Terminal for S-VHS and ED-Beta



## CB-X26 Video Cabinet for SD-281 and SD-T29

Complete with heavy-duty casters and glass doors to hold a Pioneer monitor/receiver and other components, with extra space for albums and tapes. Dimensions (W x H x D): 26<sup>3</sup>/<sub>4</sub> x 24<sup>13</sup>/<sub>16</sub> x 18<sup>11</sup>/<sub>16</sub> in. (680 x 630 x 475mm). Weight (w/o package): 63 lbs. 15 oz. (29kg).

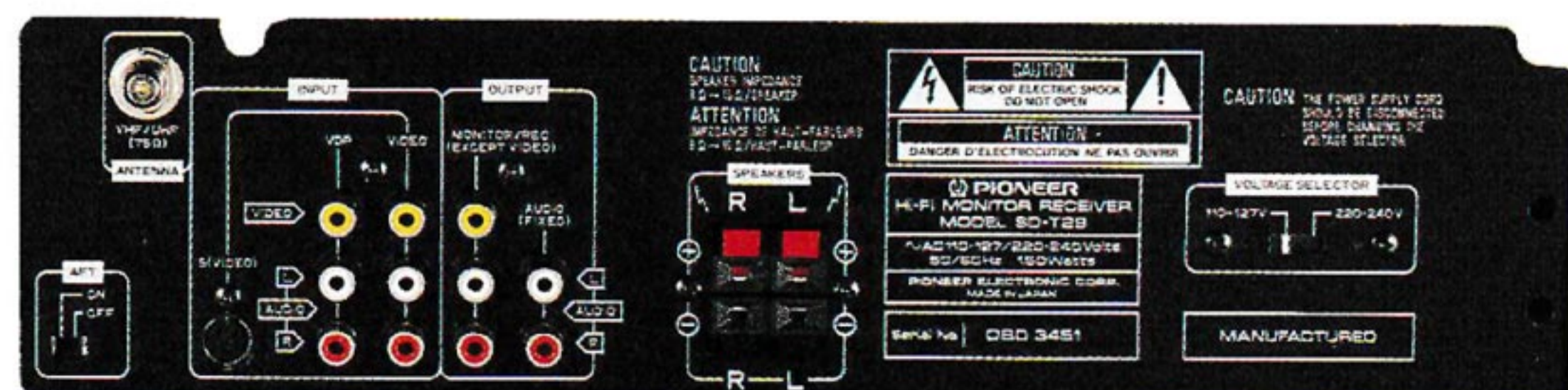

Inputs/Outputs for SD-T29

**Note:** TV pictures simulated.



# ADD-ONS & ACCESSORIES

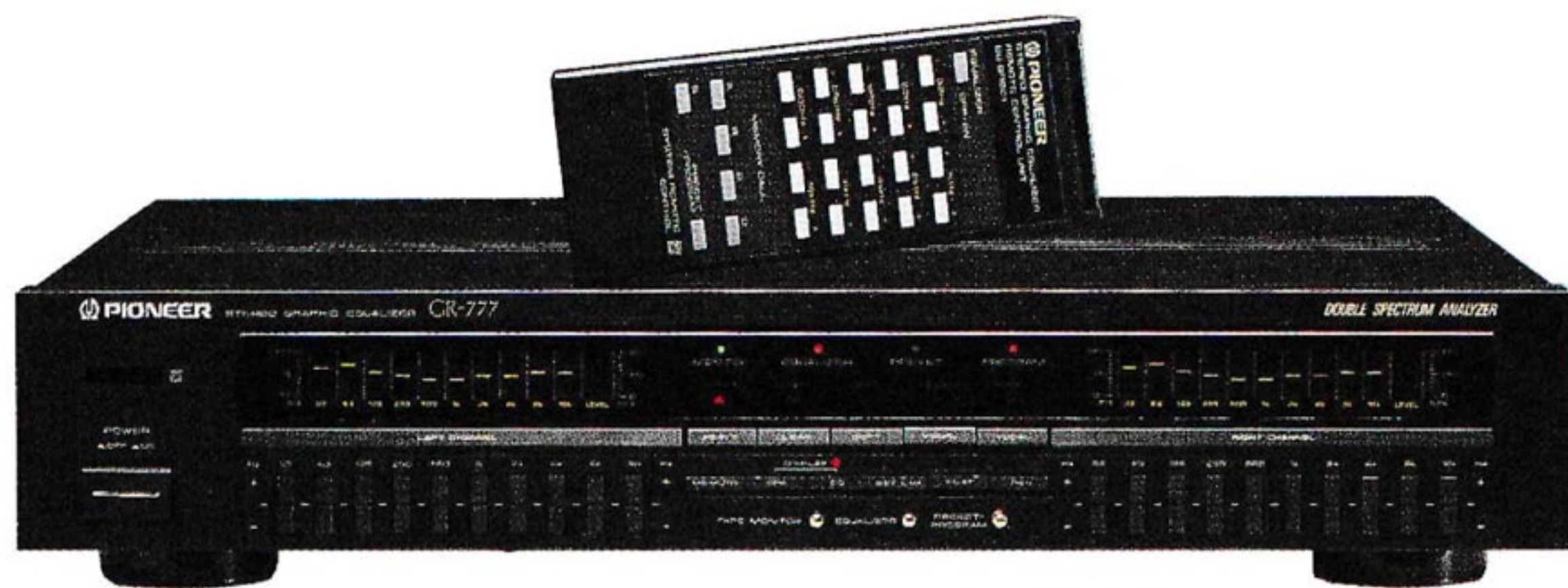

AAFES CRC No. 9294000

## GR-777 SR

### 10-Band Graphic Equalizer

- **10-Band Graphic Equalization:** Permits boost and cut ( $\pm 10\text{dB}$ ) in ten separate frequency bands — 32, 63, 125, 250, 500, 1k, 2k, 4k, 8k and 16kHz — for either or both channels.
- **Spectrum Analyzer:** Monitors frequency makeup of music in ten bands for either or both channels.
- **5 Programmable Equalization Patterns**
- **5 Resident Equalization Patterns:** Five equalized curves are stored in memory for instant recall.
- Tape Monitor
- Equalizer On/Off Switch
- Full-function remote control

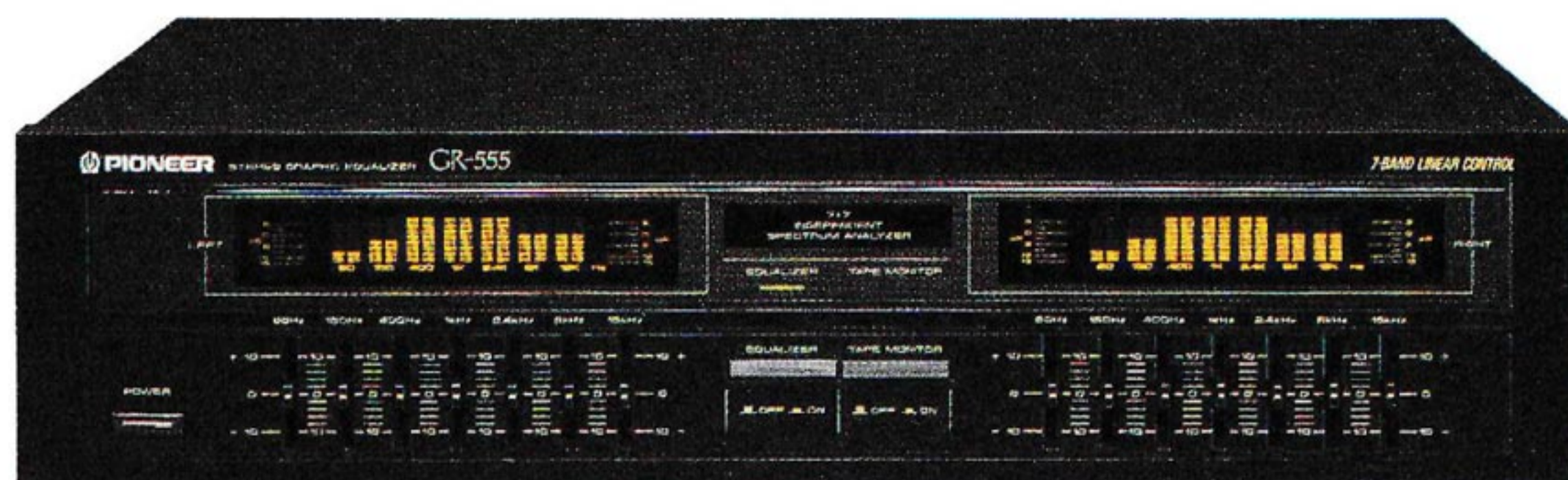

## GR-555

### 7-Band Graphic Equalizer

- **7-Band Graphic Equalization:** Permits boost and cut ( $\pm 10\text{dB}$ ) in seven separate frequency bands — 60, 150, 400, 1k, 2.4k, 6k and 15kHz — for either or both channels.
- **Spectrum Analyzer:** Monitors frequency makeup of music in seven bands for either or both channels.
- Tape Monitor Switch
- Equalizer On/Off Switch

## VSP-555: The Connection

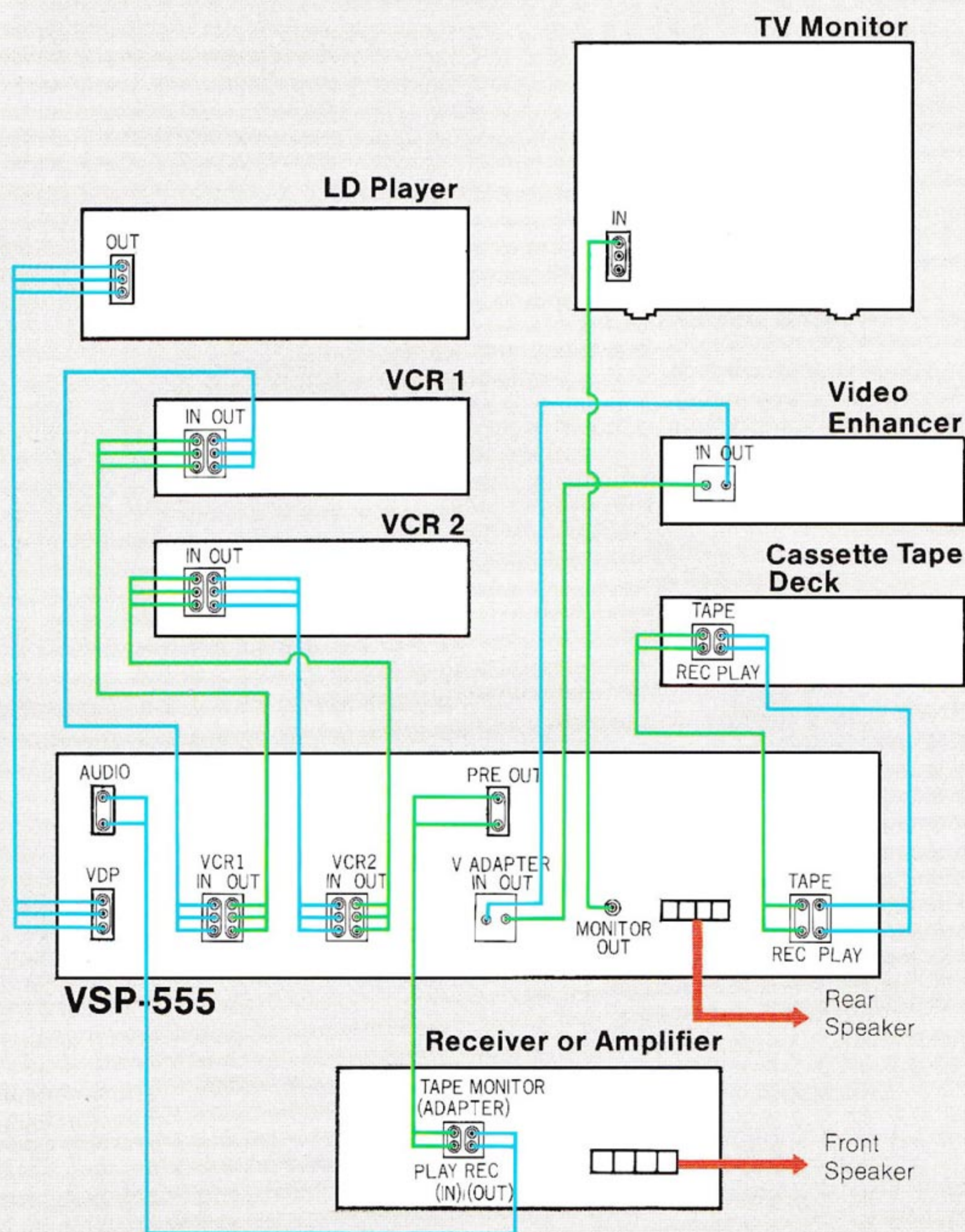

Enhancing the sound field of your AV space is easy with our VSP-555. Just connect AV sources to the VSP-555 and the audio portions are processed through its digital Dolby Surround circuit. Those for front channels are output through a connected amplifier or receiver to front speaker systems, and those for the rear "surround" effects are amplified by the VSP-555's built-in 30W amplifier and output to rear speaker systems. Add the VSP-555 to your audio system as an AV selector and Dolby Surround processor.



CATALOG CRC No. 9363631

## VSP-555 SR DOLBY SURROUND SURROUND

### AV Digital Surround Processing Amplifier

- **Surround Sound with Digital Delay for Exciting Video:** Dolby Surround, Stadium and Simulated Surround. Delay time: 15, 20, 30msec.
- **Video Selector:** LD, VCR 1, VCR 2 and 1 video adaptor.
- **Audio Signal Selector:** Lets you play sound from any connected source, irrespective of a video source.
- **Built-in Stereo Amplifier for Surround Sound:** Continuous average power output of 30 watts\* per channel, min., at 8 ohms, from 30Hz to 7,000Hz with no more than 5% total harmonic distortion
- **Full-Function Remote Control:** With surround-sound effects controls.

\* Measured pursuant to the Federal Trade Commission's Trade Regulation Rule on Power Output Claims for Amplifiers.

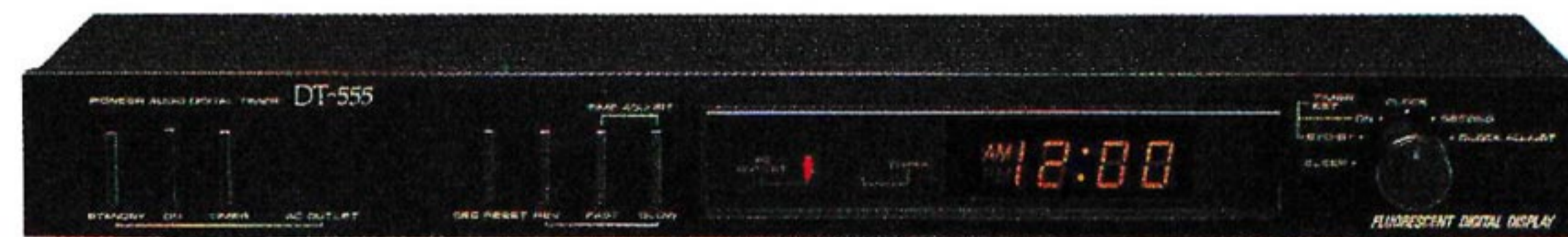

AAFES CATALOG CRC No. 9294927

## DT-555

### Audio Digital Timer

- **24-Hour Cycle Design:** Lets you turn your entire hi-fi system (or just a deck and tuner for unattended off-the-air recording) on and off once every day.
- **1-Minute Accuracy:** Controls connected equipment at precisely the right times.
- **Sleep Timer:** Automatically turns off connected equipment at your choice of time (1 minute to 1 hour 59 minutes, settable in 1-minute increments).
- **Time Adjust Controls:** Second Reset, Reverse, Fast and Slow.
- Manual AC On/Off Mode
- 2 AC Outlets

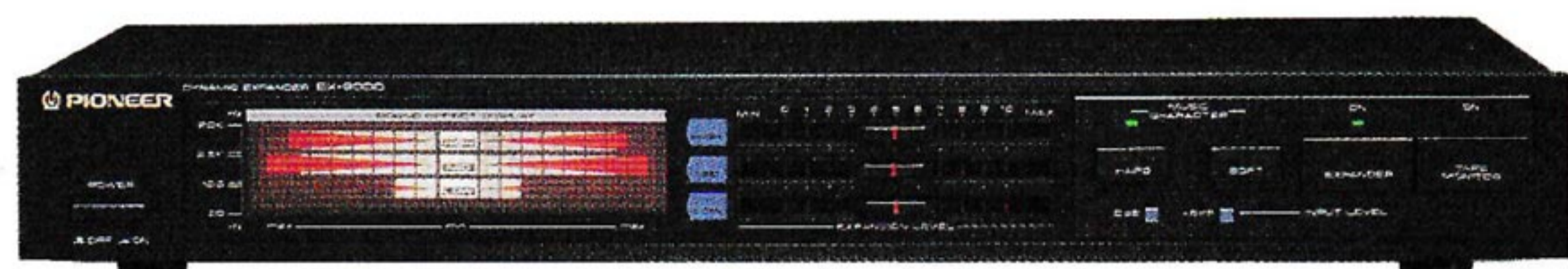

**AAFES** **CATALOG** CRC No. 9722331

## EX-9000(BK)

### Dynamic Expander

- **Dynamic Expansion:** Increases overall dynamic range of any music source.
- **3-band Adjustment:** Expansion level is adjustable band by band — lows, mids and highs.
- **“Music Character” Buttons:** “HARD” for very dynamic programs, “SOFT” for programs with little dynamic variation.
- **Fluorescent Expansion Indicator:** Attractive two-color design, divided band by band for convenience.
- **Noise Reduction:** Cleans up the “hiss” in any program material.
- **Two Input Levels:** 0dB and -6dB (latter avoids distortion with excessively high input signal).

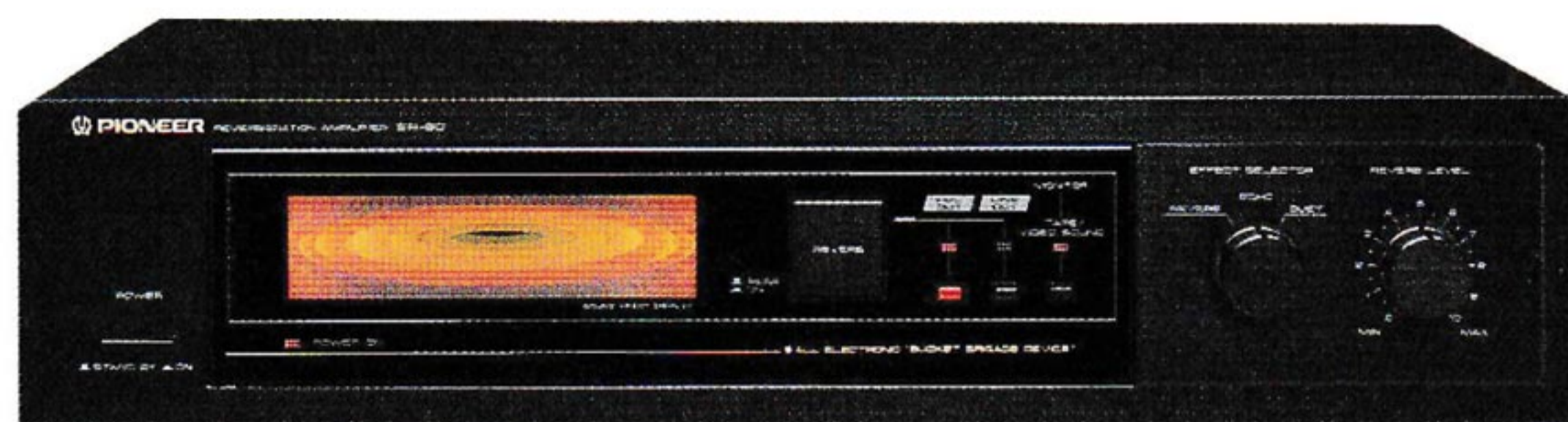

**AAFES** **CATALOG** CRC No. 9720335

## SR-60(BK)

### Reverberation Amplifier

- **Effect Selector:** Three positions are offered.  
REVERB — Simulates “Concert Hall Ambience” in any listening room.  
ECHO — Applies echo to all signals.  
DUET — Makes a solo singer sound like a duo.
- **Reverb Level Control:** Continuously adjusts the reverb time over 0 to 3 second range.
- **BBD (Bucket Brigade Device) Amp:** For natural, low-distortion application of reverberation to any program material.
- **Time/Depth Display:** Shows the amount of reverb as a pleasing visual effect.
- **Reverb Recording:** Allows you to record music with reverb added.
- **Line Output**

## AV Multifunction “Smart Remote”™

### CU-AV100 **SR**

#### Programmable Remote Control Unit

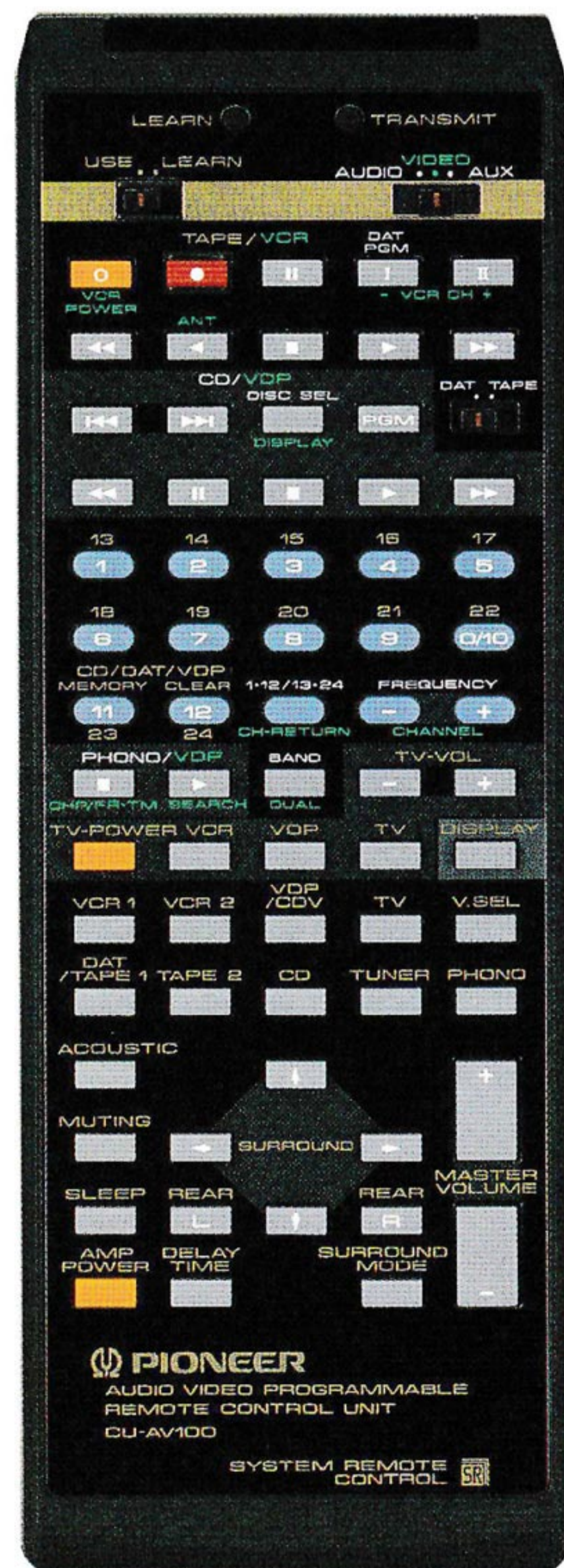

The 68-key “Smart Remote”™ control unit handles virtually every function of the components, gives you fingertip command of the major functions of other Pioneer SR components, and of the major functions of many non-Pioneer components.

With this “learning” capability, it’s easy to “teach” the remote the infrared codes for remote control of other AUDIO, VIDEO and AUXILIARY home-entertainment components, including VCRs, TVs and others. Just place it head to head near the other remote and let it “learn” the desired functions.

Keys are provided to control virtually all Pioneer AV components — CD and analog record players, DAT and analog cassette decks, tuners and AUX units, LD players, VCRs and even TVs, bearing SR mark — for play, record, pause, f-fwd/rew, track/band/channel/station and other capabilities.

Keys for versatile “Surround” and “Master” volume control are provided; the latter controls overall sound level, while the former consists of an 8-key array for L/R and F/R balance, Surround Mode selection (Dolby Surround, Stadium or Simulated) and a Delay Time selector for 15, 20 or 30 milliseconds.

**AAFES** **CATALOG**  
CRC No. 9371907

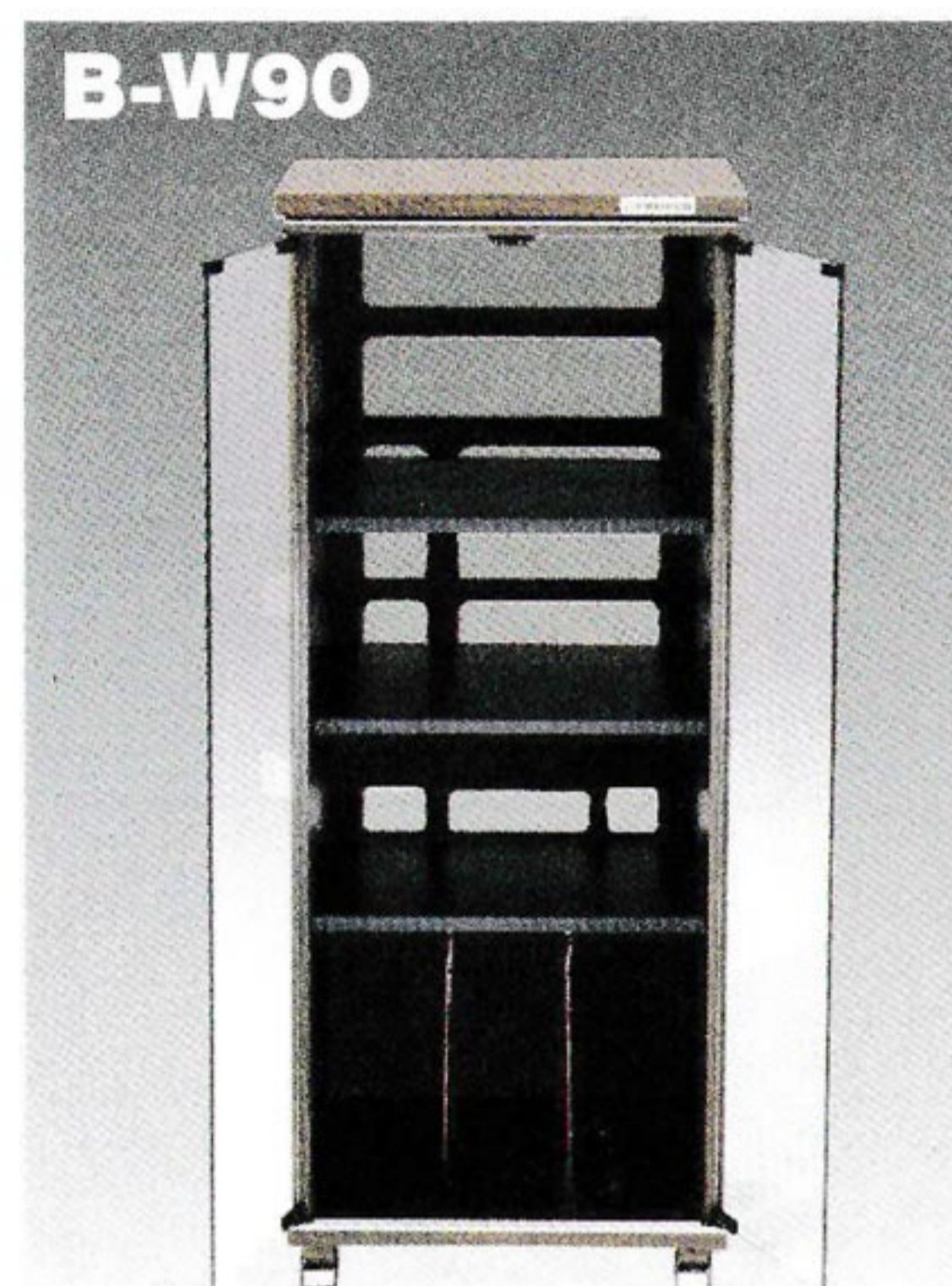

**CATALOG** CRC No. 9712209



**CATALOG** CRC No. 9376831



**AAFES** CRC No. 9441924

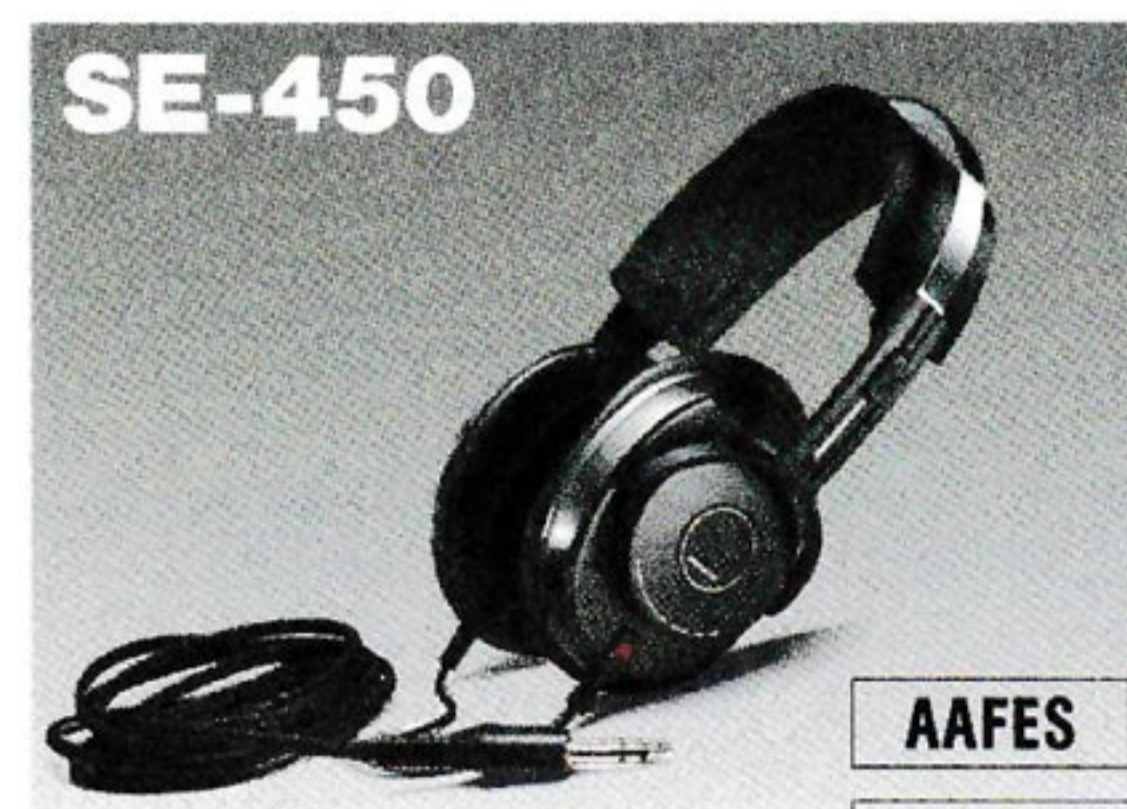

**AAFES** **CATALOG**  
CRC No. 9447434



**AAFES** **CATALOG**  
CRC No. 9026923

# SPECIFICATIONS

## Audio & Video Components

### Compact Disc Players

	PD-M900	PD-M600	PD-M500	PD-7100	PD-5100
Frequency Response (EIAJ):	4 ~ 20,000Hz ±0.5dB	4 ~ 20,000Hz ±0.5dB	4 ~ 20,000Hz ±0.5dB	4 ~ 20,000Hz ±0.5dB	4 ~ 20,000Hz ±0.5dB
Signal-to-Noise Ratio (EIAJ):	104dB	104dB	102dB	107dB	102dB
Dynamic Range (EIAJ):	96dB	96dB	92dB	97dB	92dB
Channel Separation (EIAJ):	100dB	100dB	95dB	100dB	95dB
Wow and Flutter (EIAJ):	Unmeasurable ±0.001% (weighted peak)	Unmeasurable ±0.001% (weighted peak)	Unmeasurable ±0.001% (weighted peak)	Unmeasurable ±0.001% (weighted peak)	Unmeasurable ±0.001% (weighted peak)
Distortion (EIAJ):	0.003%	0.004%	0.03%	0.0025%	0.03%
Output Voltage (EIAJ):	2.2V ±0.3Vrms	2.2V ±0.3Vrms	2.0V ±0.3Vrms	2.0V ±0.5Vrms	2.0V ±0.3Vrms
Power Requirements:	110/120 ~ 127/220/240V (switchable), 50 ~ 60Hz	110/120 ~ 127/220/240V (switchable), 50 ~ 60Hz	110/120 ~ 127/220/240V (switchable), 50 ~ 60Hz	110/120 ~ 127/220/240V (switchable), 50 ~ 60Hz	110/120 ~ 127/220/240V (switchable), 50 ~ 60Hz
Power Consumption:	18W	16W	13W	11W	13W
Dimensions (W x H x D): (without package)	17-15/16 x 4-5/16 x 12-3/8 inches 456 x 110 x 315mm	16-9/16 x 4-5/16 x 12-3/8 inches 420 x 109 x 315mm	16-9/16 x 3-15/16 x 12-3/8 inches 420 x 100 x 315mm	16-9/16 x 4-13/16 x 12-3/8 inches 420 x 123 x 315mm	16-9/16 x 3-7/8 x 12-3/8 inches 420 x 98 x 315mm
Weight (without package):	13 lbs. 10 oz./6.2kg	11 lbs. 11 oz./5.3kg	10 lbs. 12 oz./4.9kg	12 lbs. 9 oz./5.7kg	8 lbs. 9 oz./3.9kg

### AV Integrated Amplifier

VSA-910	
<b>AUDIO SECTION</b>	
Continuous Power Output: (8 ohms)	100W + 100W (20 ~ 20,000Hz, T.H.D. 0.005%)
SURROUND (Front) (8 ohms)	70W + 70W (20 ~ 20,000Hz, T.H.D. 0.005%)
(Rear) (8 ohms)	30W + 30W (20 ~ 20,000Hz, T.H.D. 0.08%)
Total Harmonic Distortion: (8 ohms)	0.005% (20 ~ 20,000Hz, continuous rated power output)
Frequency Response	
PHONO (RIAA Equalization):	20 ~ 20,000Hz ±0.3dB
CD, TUNER, TAPE, AUX, VCR, VDP:	5 ~ 100,000Hz ±0dB, -3dB
Signal-to-Noise Ratio (IHF, short-circuit A-network)	
PHONO (MM):	83dB
CD, AUX, TAPE:	96dB
VCR, VDP:	96dB
Speaker Output:	A, B, A + B, Off
<b>VIDEO SECTION</b>	
Frequency Response:	5Hz ~ 6MHz +0dB, -3dB
Crosstalk:	55dB (3.58MHz)
Signal-to-Noise Ratio:	55dB
<b>MISCELLANEOUS</b>	
Power Requirements:	110/120 ~ 127/220/240V (switchable) 50 ~ 60Hz
Power Consumption:	420W
Dimensions (W x H x D): (without package)	16-9/16 x 4-7/8 x 15-9/16 inches 420 x 124 x 396mm
Weight (without package):	24 lbs. 4 oz./11kg

### Reference Control Amplifier

C-90S	
<b>AUDIO SECTION</b>	
Rated Output:	8V (20 ~ 20,000Hz, 10k ohms, T.H.D. 0.01%)
Input Sensitivity/Impedance	PHONO (MM): 2.5mV/50k ohms (MC): 0.25mV/40 ohms or 0.125mV/3 ohms CD, TUNER, TAPE, AUX: 150mV/50k ohms
Output Level/Impedance	PRE OUT: 1V/600 ohms TAPE REC: 150mV/1k ohms
Total Harmonic Distortion:	0.002% (20 ~ 20,000Hz, 10k ohms, output 1V)
Intermodulation Distortion (50Hz : 7,000Hz = 4 : 1):	0.002% (output 1V)
Frequency Response	PHONO (RIAA Equalization): 20 ~ 20,000Hz ±0.2dB CD, TUNER, TAPE, AUX: 20 ~ 20,000Hz +0dB, -0.1dB
Tone Control	BASS: ±9dB (100Hz) TREBLE: ±9dB (10kHz)
Filter	LOW (SUBSONIC): 7Hz (-6dB/oct.) HIGH: 10kHz (-6dB/oct.)
Muting:	-20dB
Signal-to-Noise Ratio (IHF, A-network)	PHONO: 96dB (MM), 86dB (MC) CD, TUNER, TAPE, AUX: 109dB
<b>VIDEO SECTION</b>	
Input (Sensitivity/Impedance) VDP, VCR, TV Tuner, Adaptor:	1 Vp-p/75 ohms unbalanced
Output (Level/Impedance) Monitor, Adaptor, REC Monitor:	1 Vp-p/75 ohms unbalanced
Frequency Response:	10Hz ~ 10MHz +0dB, -3dB
Noise Level:	-60dB or less
<b>MISCELLANEOUS</b>	
Power Requirements:	110/120/220/240V (switchable), 50 ~ 60Hz
Power Consumption:	40W
Dimensions (W x H x D) (without package):	18 x 4-15/16 x 15-15/16 inches / 457 x 125 x 405mm
Weight (without package):	21 lbs. 5 oz./9.7kg

### Integrated Amplifiers

	A-717	A-616
Continuous Power Output: (20 ~ 20,000Hz)	100W + 100W (8 ohms, T.H.D. 0.003%) 140W + 140W (4 ohms, T.H.D. 0.005%)	80W + 80W (8 ohms, T.H.D. 0.005%) 100W + 100W (4 ohms, T.H.D. 0.008%)
Total Harmonic Distortion:	0.003% (20 ~ 20,000Hz 8 ohms, continuous rated power output) 0.005% (20 ~ 20,000Hz, 4 ohms, continuous rated power output)	0.005% (20 ~ 20,000Hz, 8 ohms, continuous rated power output) 0.008% (20 ~ 20,000Hz, 4 ohms, continuous rated power output)
Frequency Response		
PHONO (RIAA Equalization)		
MM:	20 ~ 20,000Hz ±0.2dB	20 ~ 20,000Hz ±0.2dB
MC:	20 ~ 20,000Hz ±0.3dB	20 ~ 20,000Hz ±0.3dB
CD, AUX, TAPE:	1 ~ 150,000Hz +0dB, -3dB	1 ~ 150,000Hz +0dB, -3dB
Signal-to-Noise Ratio (IHF, short-circuited A-network)		
PHONO (MM/MC):	95dB/77dB	95dB/77dB
CD, AUX, TAPE:	108dB	108dB
Speaker Output:	A, B, A + B, Off	A, B, A + B, Off
Power Requirements:	110/120 ~ 127/220/240V (switchable) 50 ~ 60Hz	110/120 ~ 127/220/240V (switchable) 50 ~ 60Hz
Power Consumption:	820W	650W
Dimensions (W x H x D): (without package)	16-9/16 x 6-3/8 x 17-1/8 inches 420 x 162 x 435mm	16-9/16 x 6-3/8 x 17-1/8 inches 420 x 162 x 435mm
Weight (without package):	41 lbs. 14 oz./19kg	30 lbs. 13 oz./14kg

### Reference Power Amplifier

M-90	
<b>POWER AMPLIFIER SECTION</b>	
Continuous Power Output: (8 ohms)	200W + 200W (20 ~ 20,000Hz T.H.D. 0.003%)
Total Harmonic Distortion: (8 ohms)	0.003% (20 ~ 20,000Hz, continuous rated power output)
Intermodulation Distortion: (50Hz: 7,000Hz = 4 : 1, 8 ohms)	0.002% (continuous rated power output)
Input Sensitivity/Impedance	
CONTROL AMP:	1V/50k ohms
CD DIRECT, LINE DIRECT:	1V/50k ohms
Output	
SPEAKERS:	A, B, A + B, Off
HEADPHONES:	Low impedance
Frequency Response:	20 ~ 20,000Hz +0dB, -0.1dB
Signal-to-Noise Ratio (IHF, A-network):	125dB
<b>MISCELLANEOUS</b>	
Power Requirements:	110/120/220/240V (switchable), 50 ~ 60Hz
Power Consumption:	430W
Dimensions (W x H x D): (without package)	18 x 6-1/16 x 16-15/16 inches 457 x 154 x 430mm
Weight (without package):	49 lbs. 13 oz./22.6kg

## Tuners

	F-91	F-443
<b>FM SECTION</b>		
Tuning Frequency Range:	88 ~ 108MHz	87.5 ~ 108MHz
Usable Sensitivity (mono):	9.8dBf (0.85µV, 75 ohms)	12.7dBf (1.2µV, 75 ohms)
50dB Quieting Sensitivity	Mono: 15.3dBf (1.6µV, 75 ohms) Stereo: 35.9dBf (17µV, 75 ohms)	18dBf (2.2µV, 75 ohms) 36.2dBf (17.7µV, 75 ohms)
Signal-to-Noise Ratio Mono/Stereo:	95dB/87dB (at 80dBf)	80dB/78dB (at 80dBf, with "Silent Servo" on)
Distortion (at 80dBf) 1kHz (mono/stereo):	0.009%/0.02%	-/0.4%
Frequency Response:	20 ~ 15,000Hz +0.2dB, -0.8dB	30 ~ 15,000Hz ±1dB
Alternate Channel Selectivity:	85dB (400kHz)	65dB (400kHz)
Stereo Separation:	65dB (1kHz), 55dB (20 ~ 10,000Hz)	45dB (1kHz)
<b>AM SECTION</b>		
Tuning Frequency Range:	530 ~ 1,600kHz	530 ~ 1,700kHz (10kHz steps)
Sensitivity - IHF, Loop Antenna:	150µV/m	300µV/m
Selectivity:	18dB	20dB
Signal-to-Noise Ratio:	50dB	50dB
<b>MISCELLANEOUS</b>		
Power Requirements:	110/120 ~ 127/220/240V (switchable), 50 ~ 60Hz	110/120 ~ 127/220/240V (switchable), 50 ~ 60Hz
Power Consumption:	25W	10W
Dimensions (W x H x D): (without package)	18 x 3-5/16 x 12-7/16 inches 457 x 84 x 316mm	16-9/16 x 2-3/4 x 12-1/2 inches 420 x 70 x 318mm
Weight (without package):	11 lbs. 7 oz./5.2kg	7 lbs. 11 oz./3.5kg

## Turntable

	PL-L70
Drive System:	Quartz-PLL direct-drive
Motor:	Quartz-PLL, coreless DC-servo motor with Stable Hanging Rotor™
Wow and Flutter (WRMS):	0.025%
Signal-to-Noise Ratio (DIN B):	80dB
Tone arm:	Statically balanced, linear-tracking tone arm with DRA
Cartridge:	Integrated IM type (PC-301)
Power Requirements:	110/120/220/240V (switchable), 50 ~ 60Hz
Power Consumption:	10W
Dimensions (W x H x D): (without package)	16-9/16 x 4-1/4 x 14-3/8 inches 420 x 108 x 365mm
Weight (without package):	11 lbs./5kg

## AV Receivers

	VSX-7300S	VSX-5300	VSX-3300
<b>AMPLIFIER SECTION</b>			
Continuous Power Output (8 ohms): Front (8 ohms): Rear (8 ohms):	125W + 125W (20 ~ 20,000Hz, T.H.D. 0.005%) 30W + 30W (1,000Hz, T.H.D. 0.7%)	100W + 100W (20 ~ 20,000Hz, T.H.D. 0.005%) 15W + 15W (1,000Hz, T.H.D. 0.7%)	80W + 80W (20 ~ 20,000Hz, T.H.D. 0.05%) — —
Total Harmonic Distortion: (8 ohms)	0.005% (20 ~ 20,000Hz, continuous rated power output)	0.005% (20 ~ 20,000Hz, continuous rated power output)	0.05% (20 ~ 20,000Hz, continuous rated power output)
Frequency Response PHONO (RIAA Equalization): CD, TAPE, AUX, VCR, VDP:	20 ~ 20,000Hz ±0.3dB 5 ~ 100,000Hz +0dB, -3dB	20 ~ 20,000Hz ±0.3dB 5 ~ 100,000Hz +0dB, -3dB	20 ~ 20,000Hz ±0.3dB 5 ~ 100,000Hz +0dB, -3dB
Signal-to-Noise Ratio (IHF, short-circuited A-network) PHONO (MM): CD, TAPE, AUX, VCR, VDP:	82dB 98dB	82dB 98dB	73dB 96dB
<b>FM TUNER SECTION</b>			
Tuning Frequency Range:	87.5 ~ 108MHz	87.5 ~ 108MHz	87.5 ~ 108MHz
Usable Sensitivity (IHF, mono):	10.8dBf (0.95µV, 75 ohms)	10.8dBf (0.95µV, 75 ohms)	10.8dBf (0.95µV, 75 ohms)
50dB Quieting Sensitivity	Mono: 15.3dBf (1.6µV, 75 ohms) Stereo: 37.1dBf (19.5µV, 75 ohms)	15.3dBf (1.6µV, 75 ohms) 37.1dBf (19.5µV, 75 ohms)	15.3dBf (1.6µV, 75 ohms) 37.1dBf (19.5µV, 75 ohms)
Signal-to-Noise Ratio	Mono: 80dB (65dBf) Stereo: 76dB (85dBf)	80dB (65dBf) 76dB (85dBf)	80dB (85dBf) 76dB (85dBf)
Distortion (at 65dBf) 1kHz (mono/stereo):	0.08%/0.15%	0.08%/0.15%	0.2%/0.3%
Frequency Response:	30 ~ 15,000Hz +0.5dB, -2dB	30 ~ 15,000Hz +0.5dB, -2dB	30 ~ 15,000Hz ±1dB
Capture Ratio:	1dB	1dB	1.2dB
Alternate Channel Selectivity:	65dB (400kHz)	65dB (400kHz)	55dB (400kHz)
Stereo Separation	1kHz: 50dB 30 ~ 15,000Hz: 35dB	48dB —	35dB —
<b>AM TUNER SECTION</b>			
Tuning Frequency Range:	530 ~ 1,700kHz (10kHz steps)	530 ~ 1,700kHz (10kHz steps)	530 ~ 1,700kHz (10kHz steps)
Sensitivity (IHF, External Antenna):	300µV/m	355µV/m	300µV/m
Selectivity:	30dB	18dB	25dB
Signal-to-Noise Ratio:	50dB	52dB	50dB
<b>VIDEO SECTION</b>			
Frequency Response:	5Hz ~ 10MHz +0dB, -3dB	5Hz ~ 10MHz +0dB, -3dB	10Hz ~ 6MHz +1dB, -2dB
Crosstalk:	55dB (3.58MHz)	55dB (3.58MHz)	55dB (3.58MHz)
Signal-to-Noise Ratio:	55dB	55dB	50dB
<b>MISCELLANEOUS</b>			
Power Requirements:	110/120 ~ 127/220/240V (switchable), 50 ~ 60Hz	110/120 ~ 127/220/240V (switchable), 50 ~ 60Hz	110/120 ~ 127/220/240V (switchable), 50 ~ 60Hz
Power Consumption:	800W	630W	595W
Dimensions (W x H x D): (without package)	16-9/16 x 6-1/8 x 16-9/16 inches 420 x 156 x 421mm	16-9/16 x 4-7/8 x 15-13/16 inches 420 x 124 x 401mm	16-9/16 x 4-3/4 x 13-1/4 inches 420 x 120 x 337mm
Weight (without package):	26 lbs. 6 oz./12.0kg	22 lbs./10.0kg	18 lbs. 1 oz./8.2kg

## Speaker Systems

	S-55TS	CS-T7000	CS-T6000	CS-907	CS-607	S-X7
Speakers						
Woofer:	5-1/2-inch (14cm) cone type x 2	12-inch (30cm) cone type	12-inch (30cm) cone type	15-3/4-inch (40cm) cone type	12-inch (30cm) cone type	3-1/2-inch (8.7cm) full-range cone type
Midrange:	—	4-3/4-inch (12cm) cone type	4-3/4-inch (12cm) cone type	6-1/2-inch (16cm) cone type	4-3/4-inch (12cm) cone type	—
Tweeter:	1-inch (2.5cm) ceramic-carbon dome type	Horn type with acoustic lens	2-5/8-inch (6.6cm) cone type	Horn type with acoustic lens	Horn type with acoustic lens	—
Supertweeter:	—	1-5/8-inch (4.2cm) x 2	Horn type	Piezoelectric supertweeter x 4	Piezoelectric supertweeter x 2	—
Impedance:	6 ohms	8 ohms	8 ohms	8 ohms	8 ohms	16 ohms
Frequency Range:	45 ~ 40,000Hz	30 ~ 20,000Hz	32 ~ 20,000Hz	30 ~ 25,000Hz	35 ~ 25,000Hz	100 ~ 20,000Hz
Sensitivity (1m):	91dB/W	93dB/W	91dB/W	99dB/W	96dB/W	90dB/W
Maximum Music Power:	120W	—	—	—	—	45W
Maximum Power:	—	240W	240W	400W	210W	—
Crossover Frequencies:	3,500Hz	1,700Hz (Low/Mid) 5,500Hz (Mid/High) 14,000Hz (High/Superhigh)	2,500Hz (Low/Mid) 6,000Hz (Mid/High) 13,000Hz (High/Superhigh)	2,000Hz (Low/Mid) 4,000Hz (Mid/High) 11,000Hz (High/Superhigh)	2,000Hz (Low/Mid) 5,000Hz (Mid/High) 11,000Hz (High/Superhigh)	— — —
Dimensions (W x H x D): (without package)	9-5/16 x 20-5/8 x 11-5/8 inches 236 x 524 x 296mm	16-1/8 x 44-7/8 x 13-3/4 inches 410 x 1140 x 350mm	14-15/16 x 36-3/4 x 13-7/16 inches 380 x 934 x 342mm	17-11/16 x 28-9/16 x 10-9/16 inches 450 x 725 x 269mm	16-1/8 x 25-7/16 x 11-1/4 inches 410 x 646 x 285mm	5-3/8 x 7-1/2 x 4-1/2 inches 136 x 190 x 115mm
Weight: (without package)	24 lbs. 10 oz./11.2kg	66 lbs. 2 oz./30kg	45 lbs. 3 oz./20.5kg	46 lbs. 3 oz./21kg	35 lbs. 4 oz./16kg	3 lbs. 5 oz./1.5kg

## Cassette Tape Decks

	CT-W900R	CT-W770R	CT-W500	CT-2080R
Type:	4-track, 2-channel twin auto-reverse stereo cassette tape deck (recording/playback x 2)	4-track, 2-channel double auto-reverse stereo cassette tape deck (recording/playback x 1, playback x 1)	4-track, 2-channel double stereo cassette tape deck (recording/playback x 1, playback x 1)	4-track, 2-channel auto-reverse recording and playback stereo cassette tape deck
Motors:	DC-servo motor for capstan drive x 2, DC motor for reel drive x 2	DC-servo motor x 2	DC-servo motor x 2	DC-servo motor for capstan drive x 1, DC motor for reel drive x 1
Heads:	"Hard Permalloy" recording/playback head x 2, Ferrite erasing head x 2	"Hard Permalloy" recording/playback head x 1, "Hard Permalloy" playback head x 1, Ferrite erasing head x 1	"Hard Permalloy" recording/playback head x 1, "Hard Permalloy" playback head x 1, Ferrite erasing head x 1	"Hard Permalloy" recording/playback head x 1, Ferrite erasing head x 1
Wow and Flutter (WRMS):	0.055%	0.055%	0.06%	0.07%
Frequency Response (-20dB)				
Normal tape:	18 ~ 17,000Hz	25 ~ 16,000Hz	25 ~ 15,000Hz	30 ~ 16,000Hz
Chrome tape:	18 ~ 18,000Hz	25 ~ 17,000Hz	25 ~ 16,000Hz	30 ~ 16,500Hz
Metal tape:	18 ~ 18,000Hz	25 ~ 18,000Hz	25 ~ 16,000Hz	30 ~ 17,000Hz
Signal-to-Noise Ratio				
Dolby off*:	58dB	57dB	56dB	58dB
dbx on:	—	92dB	—	92dB
Harmonic Distortion (0dB):	0.7%	0.7%	0.7%	0.7%
Power Requirements:	110/120 ~ 127/220/240V (switchable), 50 ~ 60Hz	110/120 ~ 127/220/240V (switchable), 50 ~ 60Hz	110/120 ~ 127/220/240V (switchable), 50 ~ 60Hz	110/120 ~ 127/220/240V (switchable), 50 ~ 60Hz
Power Consumption:	26W	25W	19W	25W
Dimensions (W x H x D): (without package)	16-9/16 x 5-3/16 x 12-1/2 inches 420 x 132 x 318mm	16-9/16 x 4-5/8 x 12-7/16 inches 420 x 116.5 x 316mm	16-9/16 x 4-5/8 x 12-7/16 inches 420 x 116.5 x 316mm	16-9/16 x 4 x 8-5/16 inches 420 x 101 x 211mm
Weight (without package):	13 lbs. 3 oz./6kg	11 lbs. 11 oz./5.3kg	11 lbs./5kg	7 lbs. 11 oz./3.5kg

\*S/N is improved by 10dB with Dolby B on, and by 19dB with Dolby C on, both at 5kHz.

## LD Players

	CLD-3030	CLD-1030	LD-850D
<b>SYSTEM</b>			
Type of Discs:	12-inch (30cm) and 8-inch (20cm) CAV/CLV LaserVision (LD) 5-inch (12cm) and 3-inch (8cm) Compact Discs 5-inch (12cm) CDV	12-inch (30cm) and 8-inch (20cm) CAV/CLV LaserVision (LD) 5-inch (12cm) and 3-inch (8cm) Compact Discs 5-inch (12cm) CDV	12-inch (30cm) and 8-inch (20cm) CAV/CLV LaserVision (LD)
<b>VIDEO CHARACTERISTICS</b>			
Horizontal Resolution:	425 lines	425 lines	425 lines
Video Signal-to-Noise Ratio:	46dB	46dB	46dB
<b>DIGITAL AUDIO CHARACTERISTICS</b>			
Frequency Response:	4 ~ 20,000Hz (±0.3dB)	4 ~ 20,000Hz (+0.5/-1.0dB)	4 ~ 20,000Hz (+0.5/-1.0dB)
Signal-to-Noise Ratio:	107dB	98dB	98dB
Dynamic Range:	95dB	95dB	95dB
Channel Separation:	107dB	92dB	92dB
Total Harmonic Distortion:	0.0035%	0.005%	0.005%
Wow and Flutter:	Unmeasurable (±0.001% weighted peak or less)	Unmeasurable (±0.001% weighted peak or less)	Unmeasurable (±0.001% weighted peak or less)
<b>OUTPUTS</b>			
Channel (VHF/NTSC):	Channel 3 or 4 (switchable)	Channel 3 or 4 (switchable)	Channel 3 or 4 (switchable)
Terminal (VHF/NTSC):	F-type jack (75 ohms, unbalanced)	F-type jack (75 ohms, unbalanced)	F-type jack (75 ohms, unbalanced)
Video Output:	RCA jack (75 ohms, unbalanced)	RCA jack (75 ohms, unbalanced)	RCA jack (75 ohms, unbalanced)
Audio Output:	RCA jacks	RCA jacks	RCA jacks
<b>MISCELLANEOUS</b>			
Power Requirements:	110/120 ~ 127/220/240V, 50 ~ 60Hz	110/120 ~ 127/220/240V, 50 ~ 60Hz	110/120 ~ 127/220/240V, 50 ~ 60Hz
Power Consumption:	55W	38W	37W
Dimensions (W x H x D): (without package)	16-9/16 x 4-5/16 x 17-5/16 inches 420 x 110 x 440mm	16-9/16 x 4-5/16 x 17-1/4 inches 420 x 110 x 438mm	16-9/16 x 4-5/16 x 17 inches 420 x 110 x 432mm
Weight (without package):	22 lbs. 7 oz./10.2kg	20 lbs. 4 oz./9.2kg	20 lbs. 7 oz./9.3kg

## Monitor/Receivers

	SD-P4002	SD-281	SD-T29
<b>DISPLAY</b>			
Reception System:	American TV standard, NTSC color	American TV standard, NTSC color	PAL/SECAM/NTSC-trident 16-system reception: PAL (I, B/G, D/K), SECAM (I, B/G, D/K, K1), NTSC M, NTSC 3.58 (I, B/G, D/K), NTSC 4.43 (I, B/G, D/K) broadcast reception; NTSC-50Hz, PAL/SECAM-60Hz playback
Screen Size:	40 in. (diagonal)	28 inches/26 inches visual size (diagonal)	29 inches/27 inches visual size (diagonal)
Horizontal Resolution:	620 lines	600 lines	600 lines
Bright (White Peak):	400 footlamberts	—	—
Actual Viewing Angle:	Horizontal = 120°, Vertical = 50°	—	—
<b>INPUTS/OUTPUTS</b>			
Inputs:	Audio/Video x 4, S-terminal x 1	Audio/Video x 3, S-terminal x 1	Audio/Video x 2, S-terminal x 1
Outputs:	Video (recording) x 1, TV x 1, audio x 1	Video (recording) x 1, audio x 1	Video (recording) x 1, audio x 1
<b>TUNER</b>			
Reception Channels:			
NTSC	VHF: CH 2 ~ CH 13 UHF: CH 14 ~ CH 69 Cable: CH A-6 ~ CCC (W + 29) (STANDARD or HRC switchable)	VHF: CH 2 ~ CH 13 UHF: CH 14 ~ CH 69 Cable: CH A-6 ~ CCC	VHF: CH 2 ~ CH 13 UHF: CH 14 ~ CH 69 Cable: CH A-6 ~ CH I, CH J ~ CH W
PAL/SECAM	—	—	VHF: CH 2 ~ CH 12 UHF: CH 21 ~ CH 69 Cable: CH X ~ CH Z + 2, CH S1 ~ CH S10, CH S11 ~ S20
Antenna Terminals:	VHF/UHF 1, 2 (75 ohms unbalanced, F connector)	VHF/UHF 1, 2 (F-type)	VHF/UHF (75 ohms unbalanced, F connector) x 1
<b>AUDIO AMPLIFIER</b>			
Continuous Power Output:	13W + 13W (1kHz, T.H.D. 10%)	11W + 11W (1kHz, T.H.D. 10%)	10W + 10W (1kHz, T.H.D. 10%)
External Speaker Impedance:	8 ohms	8 ~ 16 ohms	8 ohms or more
<b>MISCELLANEOUS</b>			
Power Requirements:	110/120/220/240V (switchable), 50 ~ 60Hz	110 ~ 120/220 ~ 240V (switchable), 50/60Hz	110 ~ 127/220 ~ 240V (switchable), 50 ~ 60Hz
Power Consumption:	275W	152W	180W
Dimensions (W x H x D): (without package)	37-1/2 x 46-3/16 x 23-1/2 inches 953 x 1173 x 597mm	26-3/4 x 22-5/8 x 19-7/8 inches 680 x 575 x 505mm	26-3/4 x 22-1/4 x 20-1/8 inches 680 x 565 x 511mm
Weight (without package):	169 lbs. 6 oz./77kg	93 lbs. 8 oz./42.5kg	91 lbs. 12 oz./41.7kg

# System Stereos

	<b>SYSTEM CD900S</b>	<b>SYSTEM CD700</b>	<b>SYSTEM E2525</b>	<b>SYSTEM CD360</b>	<b>Z-70M</b>
<b>AMPLIFIER</b>	<b>SA-1490S</b>	<b>RX-510 Amp Section</b>	<b>RX-310 Amp Section</b>	<b>RX-Z71 Amp Section</b>	<b>DC-Z81 Amp Section</b>
Continuous Power Output: (8 ohms)	130W + 130W (20~20,000Hz, T.H.D. 0.05%)	110W + 110W (20~20,000Hz, T.H.D. 0.09%)	36W + 36W (20~20,000Hz, T.H.D. 0.09%)	27W + 27W (40~20,000Hz, T.H.D. 0.3%)	36W + 36W (40~20,000Hz, T.H.D. 0.3%)
Frequency Response PHONO (RIAA Equalization): CD, TUNER, TAPE, AUX:	20 ~ 20,000Hz ±1dB 10 ~ 500,000Hz ±3dB	20 ~ 20,000Hz ±2dB 20 ~ 70,000Hz ±3dB	20 ~ 20,000Hz ±2dB 20 ~ 70,000Hz ±2dB	— —	— —
Signal-to-Noise Ratio (IHF, A-network) PHONO/AUX:	72dB/96dB	72dB/90dB	71dB/90dB	72dB	72dB
Graphic Equalizer Center Frequencies	60, 150, 400, 1k, 2.4k, 6k, 15kHz	100, 330, 1k, 3.3k, 10kHz	100, 330, 1k, 3.3k, 10kHz	100, 330, 1k, 3.3k, 10kHz	100, 330, 1k, 3.3k, 10kHz
Power Requirements:	110/120 ~ 127/220/240V, 50 ~ 60Hz	110/120 ~ 127/220/240V, 50 ~ 60Hz	110/120 ~ 127/220/240V, 50 ~ 60Hz	110/120 ~ 127/220/240V, 50 ~ 60Hz	110/120 ~ 127/220/240V, 50 ~ 60Hz
Power Consumption:	690W	680W	310W	250W	360W
Dimensions (W x H x D): (without package)	16-9/16 x 5-11/16 x 12-5/8 inches 420 x 145 x 320mm	16-9/16 x 13-11/16 x 13-1/8 inches 420 x 348 x 334mm	16-9/16 x 11 x 12-5/8 inches 420 x 280 x 320mm	14-3/16 x 12-5/16 x 13 inches 360 x 312 x 330mm	14-3/16 x 10-11/16 x 13-1/16 inches 360 x 271 x 332mm
Weight (without package):	20 lbs. 4 oz./9.2 kg	24 lbs. 5 oz./11 kg	19 lbs. 2 oz./8.7 kg	17 lbs. 10 oz./8 kg	19 lbs. 6 oz./8.8 kg
<b>TUNER</b>	<b>TX-1090Z</b>	<b>RX-510 Tuner Section</b>	<b>RX-310 Tuner Section</b>	<b>RX-Z71 Tuner Section</b>	<b>F-Z91</b>
Frequency Range	FM: 88 ~ 108MHz AM: 530 ~ 1,600kHz	FM: 87.5 ~ 108MHz AM: 530 ~ 1,700kHz	FM: 87.5 ~ 108MHz AM: 530 ~ 1,700kHz	FM: 87.5 ~ 108MHz AM: 530 ~ 1,700kHz	FM: 87.5 ~ 108MHz AM: 530 ~ 1,700kHz
FM Usable Sensitivity (mono):	12.7dBf (1µV, 75 ohms)	14.2dBf (1.4µV, 75 ohms)	14.2dBf (1.4µV, 75 ohms)	17.2dBf (2.0µV, 75 ohms)	12.5dBf (1.2µV, 75 ohms)
FM S/N Ratio (mono/stereo):	77dB/73dB (at 85dBf)	70dB/67dB (at 85dBf)	70dB/67dB (at 85dBf)	75dB/— (at 85dBf)	75dB/— (at 85dBf)
Dimensions (W x H x D): (without package)	16-9/16 x 2-3/8 x 8-7/16 inches 420 x 60 x 215mm	—	—	—	14-3/16 x 2-3/16 x 12-3/8 inches 360 x 55 x 315mm
Weight (without package):	4 lbs. 6 oz./2 kg	—	—	—	5 lbs. 1 oz./2.3 kg
<b>CASSETTE TAPE DECK</b>	<b>CT-W700R</b>	<b>RX-510 Cassette Section</b>	<b>RX-310 Cassette Section</b>	<b>RX-Z71 Cassette Section</b>	<b>DC-Z81 Cassette Section</b>
Motor	DC-servo motor x 2	DC-servo motor x 2	DC-servo motor x 2	DC-servo motor x 2	DC-servo motor x 2
Wow and Flutter (WRMS):	0.005%	0.13%	0.3%	0.2%	0.09%
Frequency Response (-20dB) Normal tape: Chrome tape: Metal tape:	25 ~ 16,000Hz 25 ~ 17,000Hz 25 ~ 18,000Hz	35 ~ 14,000Hz 35 ~ 15,000Hz —	35 ~ 14,000Hz 35 ~ 15,000Hz —	35 ~ 14,000Hz 35 ~ 15,000Hz —	35 ~ 14,000Hz 35 ~ 15,000Hz 35 ~ 16,000Hz
Signal-to-Noise Ratio Dolby off*:	57dB	50dB	50dB	56dB	56dB
Power Requirements:	110/120 ~ 127/220/240V, 50 ~ 60Hz	—	—	—	—
Power Consumption:	25W	—	—	—	—
Dimensions (W x H x D): (without package)	16-9/16 x 4-5/8 x 12-7/16 inches 420 x 116.5 x 316mm	—	—	—	—
Weight (without package):	11 lbs. 11 oz./5.3 kg	—	—	—	—
<b>TURNTABLE</b>	<b>PL-333</b>	<b>PL-310Z</b>	<b>PL 210Z</b>	<b>PL-Z81</b>	<b>PL-Z81</b>
Motor:	DC-servo motor with Stable Hanging Rotor™	DC-servo motor with Stable Hanging Rotor™	DC-servo motor with Stable Hanging Rotor™	DC-servo motor	DC-servo motor
Wow and Flutter (WRMS):	0.06%	0.07%	0.07%	0.07%	0.07%
S/N Ratio (DIN B):	68dB	68dB	68dB	63dB	63dB
Power Requirements:	110 ~ 127/220 ~ 240V, 50 ~ 60Hz	—	—	—	—
Power Consumption:	2W	—	—	—	—
Dimensions (W x H x D): (without package)	16-9/16 x 3-3/4 x 14 inches 420 x 95 x 356mm	16-9/16 x 3-3/4 x 14 inches 420 x 95 x 356mm	16-9/16 x 3-3/4 x 14 inches 420 x 95 x 356mm	14-3/16 x 3-9/16 x 13-3/4 inches 360 x 90 x 350.5mm	14-3/16 x 3-9/16 x 13-3/4 inches 360 x 90 350.5mm
Weight (without package):	6 lbs. 3 oz./2.8 kg	5 lbs. 15 oz./2.7 kg	5 lbs. 15 oz./2.7 kg	5 lbs. 15 oz./2.7 kg	5 lbs. 15 oz./2.7 kg
<b>COMPACT DISC PLAYER</b>	<b>PD-M400</b>	<b>PD-M400</b>		<b>PD-Z71</b>	<b>PD-Z81M</b>
Frequency Response (EIAJ):	4~20,000Hz +0.5dB -1.0dB	4~20,000Hz +0.5dB, -1.0dB		4 ~ 20,000Hz ±1.0dB	4 ~ 20,000Hz ±1.0dB
Signal-to-Noise Ratio (EIAJ):	More than 102dB	More than 102dB		More than 98dB	More than 98dB
Dynamic Range (EIAJ):	More than 92dB	More than 92dB		More than 92dB	More than 92dB
Wow and Flutter (EIAJ):	Unmeasurable ±0.001% (weighted peak)	Unmeasurable ±0.001% (weighted peak)		Unmeasurable ±0.001% (weighted peak)	Unmeasurable ±0.001% (weighted peak)
Distortion (EIAJ):	0.05%	0.05%			
Power Requirements:	110/120 ~ 127/220/240V, 50 ~ 60Hz	110/120 ~ 127/220/240V, 50 ~ 60Hz		110/120 ~ 127/220/240V, 50 ~ 60Hz	110/120 ~ 127/220/240V, 50 ~ 60Hz
Power Consumption:	11W	11W		11W	11W
Dimensions (W x H x D): (without package)	16-9/16 x 3-9/16 x 12-3/8 inches 420 x 90 x 315mm	16-9/16 x 3-9/16 x 12-3/8 inches 420 x 90 x 315mm		14-3/16 x 3-3/8 x 12-1/2 inches 360 x 85 x 318mm	14-3/16 x 3-3/8 x 12-1/2 inches 360 x 85 x 318mm
Weight (without package):	10 lbs. 5 oz./4.7 kg	10 lbs. 5 oz./4.7 kg		7 lbs. 4 oz./3.3 kg	10 lbs. 2 oz./4.6 kg
<b>SPEAKER SYSTEM</b>			<b>CS-579</b>	<b>CS-579</b>	<b>S-Z81D</b>
Speakers:			7-7/8-inch (20cm) cone woofer, 2-5/8-inch (6.6cm) cone tweeter, 2-1/16 inch (5.2 cm) cone supertweeter	7-7/8-inch (20cm) cone woofer, 2-5/8-inch (6.6cm) cone tweeter, 2-1/16-inch (5.2cm) cone supertweeter	9-1/16-inch (23cm) cone woofer, 2-5/8-inch (6.6cm) cone tweeter 11/16-inch (1.8cm) dome supertweeter.
Impedance:			8 ohms	8 ohms	6 ohms
Frequency Range:			45 ~ 20,000Hz	45 ~ 20,000Hz	48 ~ 20,000Hz
Sensitivity (at 1m):			90dB/W	90dB/W	91dB/W
Maximum Music Power:			60W	60W	75W
Dimensions (W x H x D): (without package)			11 x 26-15/16 x 8-3/4 inches 280 x 684 x 222mm	11 x 26-15/16 x 8-3/4 inches 280 x 684 x 222mm	10-5/8 x 17-13/16 x 8-1/4 inches 270 x 453 x 210mm
Weight (without package):			14 lbs. oz./6.5 kg	14 lbs. 5 oz./6.5 kg	11 lbs./5 kg
<b>AUDIO CABINET</b>	<b>CB-F900</b>	<b>CB-F900</b>	<b>CB-F130</b>	<b>CB-Z71</b>	
Dimensions (W x H x D): (without package)	18-13/16 x 44-7/8 x 19-3/16 inches 478 x 1140 x 487mm	18-13/16 x 44-7/8 x 19-3/16 inches 478 x 1140 x 487mm	19 x 33-1/16 x 18-3/4 inches 484 x 840 x 477mm	18-9/16 x 36-3/4 x 18-1/8 inches 472 x 934 x 460mm	
Weight (without package):	71 lbs. 12 oz./32.5 kg	71 lbs. 12 oz./32.5kg	50 lbs. 10 oz./23 kg	52 lbs. 13 oz./24 kg	

\*S/N is improved by 10dB with Dolby B on, and by 19dB with Dolby C on, both at 5kHz.

# Add-On Components

## Graphic Equalizers

	GR-777	GR-555
Equalizer Range:	±10dB	±10dB
Center Frequencies:	32, 63, 125, 250, 500, 1k, 2k, 4k, 8k, 16kHz	60, 150, 400, 1k, 2.4k, 6k, 15kHz
Total Harmonic Distortion:	0.02% (20 ~ 20,000Hz, output 1V)	0.03% (20 ~ 20,000Hz, output 1V)
Signal-to-Noise Ratio:	110dB (IHF A-network, output 1V)	104dB (IHF A-network, output 1V)
Frequency Response:	5 ~ 70,000Hz +0dB, -3dB	10 ~ 50,000Hz +0dB, -3dB
Power Requirements:	110/120 ~ 127/220/240V (switchable) 50 ~ 60Hz	110/120 ~ 127/220/240V (switchable) 50 ~ 60Hz
Power Consumption:	18W	15W
Dimensions (W x H x D): (without package)	16-9/16 x 3-3/8 x 12-1/4 inches 420 x 85.5 x 311.5mm	16-9/16 x 4-1/8 x 13-1/8 inches 420 x 105 x 334mm
Weight (without package):	8 lbs. 13 oz./4.0 kg	9 lbs. 4 oz./4.2 kg

## Surround Amplifier

	VSP-555*
<b>AUDIO SECTION</b>	
Continuous Power Output:	30W + 30W (8 ohms, 30 ~ 7,000Hz, T.H.D. 5%)
Frequency Response:	10 ~ 70,000Hz +0dB, -3dB
Signal-to-Noise Ratio (IHF, short-circuited A-network):	90dB
<b>VIDEO SECTION</b>	
Frequency Response:	5Hz ~ 6MHz +0dB, -3dB
Signal-to-Noise Ratio:	55dB
<b>MISCELLANEOUS</b>	
Power Requirements:	110/120 ~ 127/220/240V (switchable) 50 ~ 60Hz
Power Consumption:	180W
Dimensions (W x H x D): (without package)	16-9/16 x 4-3/4 x 13-1/4 inches 420 x 120 x 336mm
Weight (without package):	12 lbs. 6 oz./5.6 kg

\*Specifications for the VSP-555 are tentative.

## Reverberation Amplifier

	SR-60 (BK)
Reverberation Time (DEPTH volume control Min.)	
Reverb:	0 ~ 3 sec. (400Hz)
Echo:	0 ~ 3 sec. (400Hz)
Duet:	100msec. (400Hz)
Maximum Output Voltage:	6.5V (1kHz, T.H.D. 0.01%)
Total Harmonic Distortion:	0.005% (1kHz, REVERB LEVEL Min., output 1V)
Frequency Response:	10 ~ 70,000Hz +0dB, -1dB
Signal-to-Noise Ratio: (IHF, A-network)	104dB (output 2V), 98dB (output 1V)
Power Requirements:	110/120 ~ 127/220/240V (switchable) 50 ~ 60Hz
Power Consumption:	30 watts
Dimension (W x H x D): (without package)	16-9/16 x 3-7/8 x 13-3/8 inches 420 x 99 x 340mm
Weight (without package):	10 lbs. 2 oz./4.6 kg

## Audio Digital Timer

	DT-555
Timer Type:	24-hour type (12-hour display and AM/PM)
Timer Set:	Only one ON/OFF time setting in minimum units of minutes within a 24-hour period
Sleep Timer Set:	1 minute ~ 1 hour 59 minutes
Accuracy of Timer:	±0.1 second (delay time to displayed time)
AC Outlet Capacity Power:	1,200W (max.)
Power Requirements:	110/120/220/240V (switchable) 50 ~ 60Hz
Power Consumption:	6W
Dimensions (W x H x D): (without package)	16-9/16 x 2-1/16 x 5-9/16 inches 420 x 52 x 142mm
Weight (without package):	3 lbs. 12 oz./1.7 kg

## Dynamic Expander

	EX-9000 (BK)		
Dynamic Range (max.)	Low (50Hz)	Mid (500Hz)	High (5kHz)
Expansion Level:	17dB	12dB	17dB
Upward Gain:	+15dB	+7dB	+12dB
Downward Gain:	-2dB	-5dB	-5dB
Impulse Response			
Attack Time:	4.7msec.		
Release Time:			
Hard Position	68msec.		
Soft Position	2.7 sec.		
Signal-to-Noise Ratio: (IHF, A-network, 1kHz, all expansion level max.)	96dB (output 1V)		
Power Requirements:	110/120 ~ 127/220/240V (switchable), 50 ~ 60Hz		
Power Consumption:	28W		
Dimensions (W x H x D): (without package)	16-9/16 x 2-3/8 x 8-5/16 inches 420 x 60 x 212mm		
Weight (without package):	7 lbs. 1 oz./3.2 kg		

Note: All specifications and designs subject to modification without notice.

In the Pacific and European areas, Pioneer products are available at Army & Air Force, Navy, Marine Corps Exchanges and also through:

**EXCHANGE MAIL ORDER CATALOG** — AAFES Catalog Sales, P.O. Box 660211, Dallas, TEXAS 75266-0211

Note: Please check Exchange Catalog items in Exchange Catalogs at your nearest Exchange Counter.

 **PIONEER®**

For more information, please write to:

**PIONEER ELECTRONIC CORPORATION**

4-1, Meguro 1-chome, Meguro-ku, Tokyo 153, Japan

**PIONEER ELECTRONIC GmbH**

Isenburg Park, Schleussnerstraße 92, 6078 Neu Isenburg, West Germany

Published by Pioneer Electronic Corporation. Copyright 1988 by Pioneer Electronic Corporation. All rights reserved.