

KENWOOD

CD CDV LD PLAYER

LVD-300

INSTRUCTION MANUAL

KENWOOD CORPORATION



B60-0164-00 (JA) (K, Y) II
91/12 11 10 9 8 7 6 5 4 3 2 1 90/12 11 10 9 8 7 6

Introduction

Your choice of this product indicates that you are a devotee to excellence in sound reproduction.

We appreciate your patronage and take pride in the long tradition of quality components that our company represents.

So that you can get the most out of your unit, we suggest that you take the time to read through this manual before you hook up and operate your system. This will acquaint you with operating features and system-connection considerations so that your listening pleasure will be enhanced right from the start. You will notice that in all aspects of planning, engineering, styling, operating convenience and adaptability we have sought to anticipate your needs and desires.

Keep this manual handy for future reference.

For your records

Record the serial number, found on the back of the unit, in the spaces designated on the warranty card, and in the space provided below. Refer to the model and serial numbers whenever you call upon your dealer for information or service on this product.

Model _____ Serial Number _____

Unpacking

Unpack the unit carefully and make sure that all accessories are put aside so they will not be lost.

Examine the unit for any possibility of shipping damage. If your unit is damaged or fails to operate, notify your dealer immediately. If your unit was shipped to you directly, notify the shipping company without delay. Only the consignee (the person or company receiving the unit) can file a claim against the carrier for shipping damage.

We recommend that you retain the original carton and packing materials for use should you transport or ship the unit in the future.

For the USA

CAUTION:

Use of controls or adjustments or performance of procedures other than those specified herein may result in hazardous radiation exposure.

In compliance with Federal Regulations, following are reproductions of labels on, or inside the product relating to laser product safety.

KENWOOD CORPORATION
SHIONOGI SHIBUYA BUILDING 17-5,
2-CHOME, SHIBUYA, SHIBUYA-KU,
TOKYO, JAPAN

KENWOOD CORP. CERTIFIES THIS EQUIPMENT
CONFORMS TO DHHS REGULATIONS NO. 21 CFR
1040. 10, CHAPTER I, SUBCHAPTER J.

Location: Back Panel

DANGER

INVISIBLE LASER RADIATION WHEN OPEN AND INTERLOCK FAILED OR DEFEATED.
AVOID DIRECT EXPOSURE TO BEAM.

Location: Inside, near the Laser mechanism.

For the U.S.A.

Note to CATV system installer:

This reminder is provided to call the CATV system installer's attention to Article 820-40 of the NEC that provides guidelines for proper grounding and, in particular, specifies that the cable ground shall be connected to the grounding system of the building, as close to the point of cable entry as practical.

Accessories

Remote control unit.....1



Audio cord1



Video cord.....1



Battery ("AA" or "R6")2



System control cord1



Antenna adapter1
(Except for some areas.)



Coaxial cable1
(Except for some areas.)



RF Modulator (RFM-100)1
(Except for some areas.)

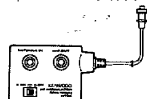

Contents

Caution: Read the pages marked carefully to ensure safe operation.

Introduction.....	2
▲ Before applying power	3
▲ Safety precautions	3
▲ IMPORTANT SAFEGUARDS	4
Before operation.....	6
System connections.....	9
Controls and indicators.....	14
Remote control operation.....	15
Normal playback operation (CD, CDV, LD).....	16
Searching for a desired scene (tune) (CD, CDV, LD)	18

Audio switching	21
Special video playback functions (LD-CAV)	22
Program play (CD, CDV, LD)	24
Editing	26
Repeat play	28
Random play	29
Switching the time display	30
Useful functions.....	31
In case of difficulty	32
Specifications	34

LVD-300

CORRECTION SHEET

Specifications

INCORRECT	CORRECT
<p>Digital audio section</p> <p>Frequency response4 Hz~20 kHz</p> <p>Signal to noise ratioMore than 105 dB</p> <p>Dynamic range.....More than 98 dB</p> <p>Total harmonic distortionLess than 0.007% (1 kHz)</p> <p style="text-align: center;">↑</p>	<p>Digital audio section</p> <p>Frequency response4 Hz~20 kHz</p> <p>Signal to noise ratioMore than 105 dB</p> <p>Dynamic range.....More than 98 dB</p> <p>Total harmonic distortionLess than 0.004% (1 kHz)</p>

Before applying power

For the U.S.A. and Canada

Important!

Units shipped to the U.S.A. and Canada are designed for operation on 120 volts AC only.

Safety precaution for a Polarized AC plug

However, some products may be supplied with a non-polarized plug.

CAUTION: TO PREVENT ELECTRIC SHOCK DO NOT USE THIS (POLARIZED) PLUG WITH AN EXTENSION CORD, RECEPTACLE OR OTHER OUTLET UNLESS THE BLADES CAN BE FULLY INSERTED TO PREVENT BLADE EXPOSURE.

For the United Kingdom

Important!

Units shipped to the U.K. are designed for operation on 240 volts AC only.

The mains plug must be removed from the wall socket prior to any internal examination.

The wires in this mains lead are coloured in accordance with the following code:

Blue Neutral
Brown Live

The wires in this mains lead must be connected to the terminals in the plug as follows:

Wire colour	Plug terminal marking
Blue	N or Black
Brown	L or Red

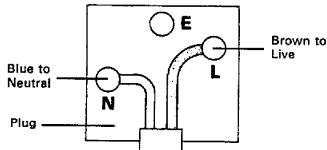

Notes:

1. If a 13-amp plug is used, this must be fitted with a 5-amp fuse.
2. If a 3-pin plug with earthing contact is used, no wire must be connected to the E terminal.

For Australia and Europe

Important!

Units shipped to Australia are designed for operation on 240 V AC only.

Units shipped to Europe are designed for operation on 220 V AC only.

For other countries

Important!

Units shipped to countries other than the above countries are equipped with an AC voltage selector switch on the rear panel. Refer to the following paragraph for the proper setting of this switch.

AC voltage selection

This unit operates on 110-120 or 220-240 volts AC. The AC voltage selector switch Type A or Type B on the rear panel is set to the voltage that prevails in the area to which the unit is shipped. Before connecting the power cord to your AC outlet, make sure that the setting position of this switch matches your line voltage. If not, it must be set to your voltage in accordance with the following direction.

Note:

Our warranty does not cover damage caused by excessive line voltage due to improper setting of the AC voltage selector switch.

AC voltage selector switch

Type A

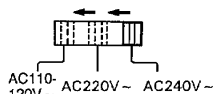



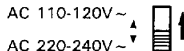

Type B



Move switch lever to match your line voltage with a small screwdriver or other pointed tool.

Safety precautions

WARNING: TO PREVENT FIRE OR SHOCK HAZARD, DO NOT EXPOSE THIS APPLIANCE TO RAIN OR MOISTURE.

 <div style="border: 1px solid black; padding: 5px; text-align: center;"> CAUTION <small>RISK OF ELECTRIC SHOCK DO NOT OPEN</small> </div> 	<p>CAUTION: TO REDUCE THE RISK OF ELECTRIC SHOCK, DO NOT REMOVE COVER (OR BACK). NO USER-SERVICEABLE PARTS INSIDE, REFER SERVICING TO QUALIFIED SERVICE PERSONNEL.</p>
	<p>THE LIGHTNING FLASH WITH ARROWHEAD SYMBOL, WITHIN AN EQUILATERAL TRIANGLE, IS INTENDED TO ALERT THE USER TO THE PRESENCE OF UNINSULATED "DANGEROUS VOLTAGE" WITHIN THE PRODUCT'S ENCLOSURE THAT MAY BE OF SUFFICIENT MAGNITUDE TO CONSTITUTE A RISK OF ELECTRIC SHOCK TO PERSONS.</p>
	<p>THE EXCLAMATION POINT WITHIN AN EQUILATERAL TRIANGLE IS INTENDED TO ALERT THE USER TO THE PRESENCE OF IMPORTANT OPERATING AND MAINTENANCE (SERVICING) INSTRUCTIONS IN THE LITERATURE ACCOMPANYING THE APPLIANCE.</p>

IMPORTANT SAFEGUARDS

⚠ Caution : Read this page carefully to ensure safe operation.

Please read all of the safety and operating instructions before operating this unit. For best results, follow all warnings placed on the unit and adhere to the operating and use instructions. These safety and operating instructions should be retained for future reference.

1. Power sources — The unit should be connected to a power supply only of the type described in the operating instructions or as marked on the appliance.

2. Power-cord protection — Power-supply cords should be routed so that they are not likely to be walked on or pinched by items placed upon or against them, pay particular attention to cords at plugs, convenience receptacles, and the point where they exit from the unit.

Never pull or stretch the cord.



3. Grounding or polarization — The precautions should be taken so that the grounding or polarization means of this unit is not defeated.

4. Ventilation — The unit should be situated so that its location or position does not interfere with its proper ventilation.

To maintain good ventilation, do not put records or a table-cloth on the unit. Place the unit at least 10 cm away from the walls.

Do not use the unit on a bed, sofa, rug or similar surface that may block the ventilation openings.

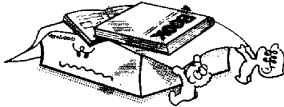

5. Water and moisture — The unit should not be used near water — for example, near a bathtub, washbowl, kitchen sink, laundry tub, in a wet basement, or near a swimming pool, etc.

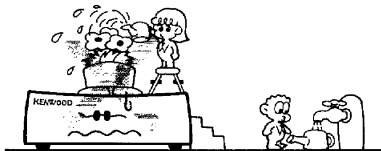

6. Temperature — The unit may not function properly if used at extremely low, or freezing temperatures. The ideal ambient temperature is above +5°C (41°F).

7. Heat — The unit should be situated away from heat sources such as radiators, heat registers, stoves, or other units (including amplifiers) that produce heat.

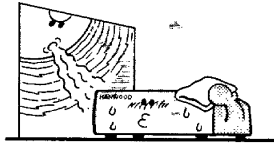

8. Electric shock — Care should be taken so that objects do not fall and liquid is not spilled into the enclosure through openings. If a metal object, such as a hair pin or a needle, comes into contact with the inside of this unit, a dangerous electric shock may result. For families with children, never permit children to put anything, especially metal, inside this unit.



9. Enclosure removal — Never remove the enclosure. If the internal parts are touched accidentally, a serious electric shock might occur.

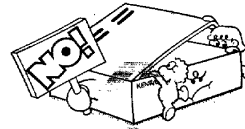

10. Magnetic fields — Keep the unit away from sources of magnetic fields such as TV sets, speaker systems, radios, motorized toys or magnetized objects.

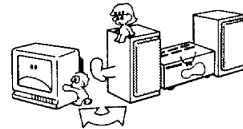

11. Cleaning — Do not use volatile solvents such as alcohol, paint thinner, gasoline, or benzine, etc. to clean the cabinet. Use a clean dry cloth.

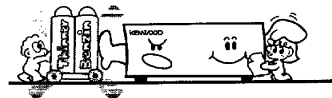

- 12. Carts and stands** — An appliance and cart combination should be moved with care. Quick stops, excessive force, and uneven surfaces may cause the appliance and cart combination to overturn.



- 13. Nonuse periods** — The power cord of the unit should be unplugged from the outlet when left unused for a long period of time.

- 14. Abnormal smell** — If an abnormal smell or smoke is detected, immediately turn the power OFF and pull out the power cord. Contact your dealer or nearest service center.

POWER OFF!



- 15. Damage requiring service** — The unit should be serviced by qualified service personnel when:

- A. The power-supply cord or the plug has been damaged; or
- B. Objects have fallen, or liquid has been spilled into the unit; or
- C. The unit has been exposed to rain; or
- D. The unit does not appear to operate normally or exhibits a marked change in performance; or
- E. The unit has been dropped, or the enclosure damaged.

- 16. Servicing** — The user should not attempt to service the unit beyond that described in the operating instructions. All other servicing should be referred to qualified service personnel.

- 17. Outdoor antenna grounding** — If an outside antenna is connected to the receiver, be sure the antenna system is grounded so as to provide some protection against voltage surges and built up static charges. Section 810 of the National Electrical Code, ANSI/ NFPA No. 70—1984, provides information with respect to proper grounding of the mast and supporting structure, grounding of the lead-in wire to an antenna discharge unit, size of grounding con-

ductors, location of antenna-discharge unit, connection to grounding electrodes, and requirements for the grounding electrode. See Figure.

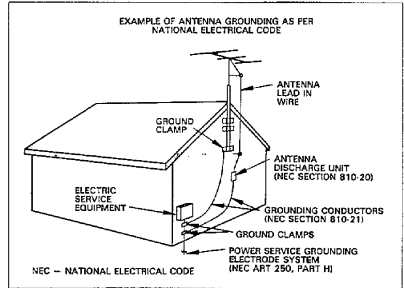

- 18. Power lines** — An outdoor antenna should be located away from power lines.

Notes:

- 1. Item 3 is not required except for grounded or polarized equipment.
- 2. Item 17 and 18 are not required except for units provided with antenna terminals.
- 3. Item 17 complies with UL in the U.S.A.

Before operation

Discs which can be played with this unit

Disc types



1. With this unit, use discs which bear one of the logos shown at the left.
2. This unit cannot be used with CED or VHD type video discs.
3. This unit conforms to the NTSC system. Discs indicated for use with other television systems (PAL, SECAM) cannot be used with this unit.

Disc sizes

CD single
8 cm



One side only,
Audio: 20 minutes
max.

CD
12 cm



One side only,
Audio: 74 minutes
max.

CDV
12 cm



One side only,
Audio: 20 minutes
max.
Video: 5 minutes
max.

LD single
20 cm



CAV: One side 14 minutes
max.

CLV: One side 20 minutes
max.

(This unit can play even
thin-type 20 cm LD sin-
gles without requiring an
adaptor.)

LD
30 cm

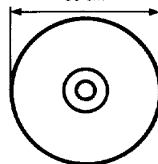

CAV: One side 30 minutes max.

CLV: One side 60 minutes max.

CAV discs (Standard Play discs)

Discs of this type spin at a fixed rotational speed (Constant Angular Velocity) of 1800 rpm. Each revolution is equivalent to one video frame, and each frame is assigned its own frame number. Special video playback functions such as still frame, frame advance, and multi-speed playback are available with this disc type.

CLV discs (Extended Play discs)

When a CLV disc is played, the rotational velocity is varied as the playback position moves from the inside to the outside of the disc, thus maintaining a Constant Linear Velocity. Discs of this type are recorded with the time numbers which indicate the elapsed play time from the beginning of the disc. Although special video playback functions are not possible with CLV discs, CLV discs offer longer playback time compared to CAV discs.

Precautions when transporting or moving this unit

Before transporting or moving this unit, carry out the following operations.

1. Turn the power ON but do not load a disc.
2. Wait a few seconds and verify that the display shown at the right appears.
3. Turn the power OFF.

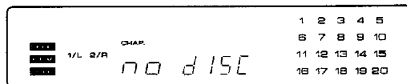

Disc Handling Precautions



with LDs



with CDs and CDV discs

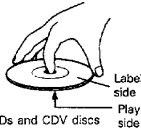

Handling

Hold the disc so that you do not touch the playback side.

Do not attach anything such as tape or paper to either the playback side or the label side.

Cleaning

To remove fingerprints or dirt from a disc, gently wipe the disc with a soft cloth in a radial direction (straight from the center to the edge).

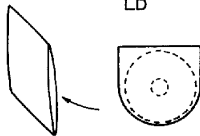
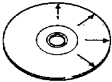

Storage

If a disc is not to be used, remove it from the unit and store it in its case.

Disc Use Precautions



Do not use cracked or warped discs

During play, a disc rotates at very high speeds inside the player. Never use cracked or defective discs or discs which are noticeably warped. Use of such a disc may damage the player.

CX Noise Reduction System

Display area

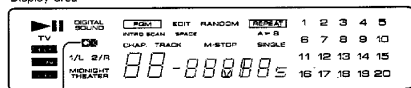

indicator



This unit realizes low-noise, powerful sound reproduction through the use of the CX Noise Reduction System. When a disc bearing the mark is played, this system automatically operates and the indicator lights in the display.

- If the indicator does not light when playing a disc which bears the mark, press the key on the remote control unit so that the indicator appears.

Beware of condensation

When water vapor comes into contact with the surface of cold material, water drops are produced.

If condensation occurs, correct operation may not be possible, or the unit may not function correctly.

This is not a malfunction, however, and the unit should be dried. (To do this, turn the POWER switch ON and leave the unit as it is for several hours.)

Be especially careful in the following conditions:

- When the unit is brought from a cold place to a warm place, and there is a large temperature difference.
- When a heater starts operating.
- When the unit is brought from an air-conditioned place to a place of high temperature with high humidity.
- When there is a large difference between the internal temperature of the unit and the ambient temperature, or in conditions where condensation occurs easily.

CD/CDV/LD terminology

Chapter number (LD)

Like a book, LDs are divided into "chapters," each of which is assigned a chapter number. Chapter numbers are used on the jacket cover to designate the disc contents. Using these chapter numbers, you can use functions such as the Chapter Search function which enables you to quickly locate desired scenes.

- Some discs are not recorded with chapter numbers.

Frame number (LD)

"Frame" is the name given to each image recorded on a standard play (CAV) disc, and is equivalent to a "page" in a book. By designating frame numbers recorded on the disc, you can carry out operations such as Frame Search which allows you to begin playback from a desired scene.

Time number (LD)

Time numbers are recorded on extended play (CLV) discs and indicate the elapsed play time from the beginning of the disc. Operations such as Time Search can be carried out using these time numbers. Time numbers are recorded in second units or minute units, depending on the disc.

Track number (CD, CDV)

Track numbers are used to designate the various sections of a disc. CDV discs are recorded with track numbers which continue in sequence from the audio part to the video part. Using these track numbers, you can carry out functions such as Track Search to quickly find a desired tune.

TOC (CD, CDV, LD)

In addition to audio signals, all CDs and CDV discs are recorded with a data section called a TOC (Table of Contents) at the beginning of the disc. The TOC is equivalent to the table of contents of a book and contains information such as the track number and playing time of each tune.

- Some LDs are also provided with a TOC.

System connections

Make connection as shown in the diagram below. When connecting the related system components, refer also to the instruction manuals of the related components.

Do not plug in the power lead until all connections are completed.

■ Basic connection

- If you have an amplifier which can switch video signals, connect the output jacks of this player to the amplifier's input jacks.
- If you have an amplifier which cannot switch video signals, connect the audio output jacks of this player to the input jacks of the amplifier and connect the video signal to your TV's video input jack.
- If your TV does not have a video input jack, use an RF modulator (RFM-100) to connect the video signal to your TV's antenna terminal. For details, see "Connection using an RF modulator" on page 10.
- If your TV has an S-VIDEO terminal, use an S-VIDEO cable to connect the S-VIDEO terminals of the TV and the player.

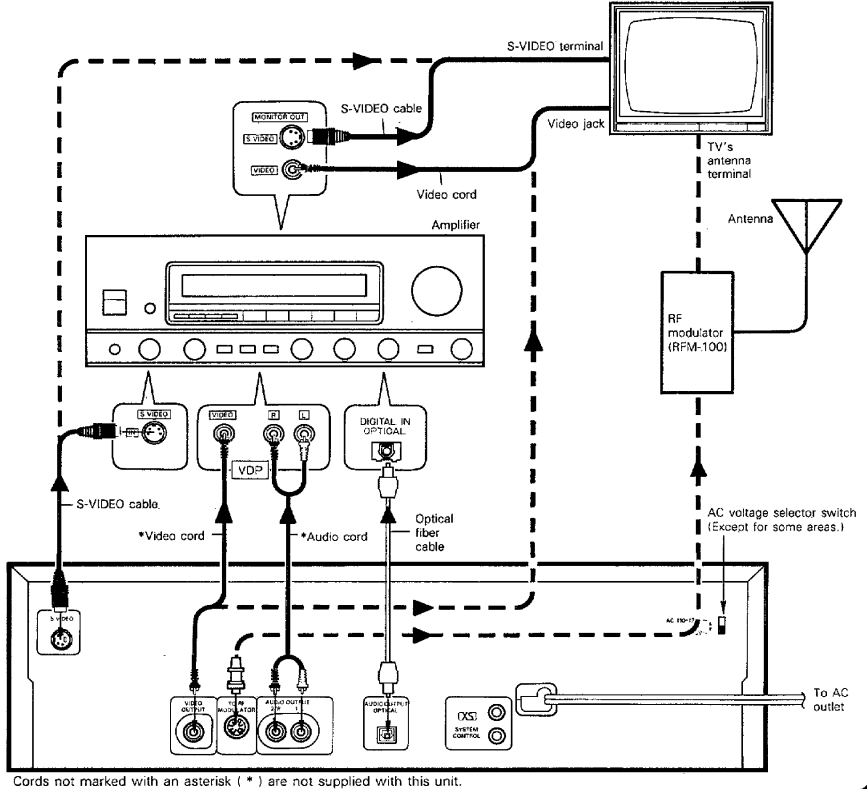



Notes:

1. Connect all cords firmly. If connections are loose there could be loss of sound or noise produced.
2. When plugging and unplugging connection cords after connections are complete, be sure to first remove the power cord from the AC outlet. Plugging/unplugging connection cords without removal of the power cord can cause malfunctions or damage to the unit.

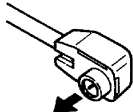
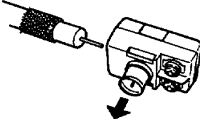
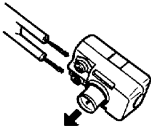
**■ Connection using an RF modulator (connection to the TV's antenna terminal)
(Except for some areas)**

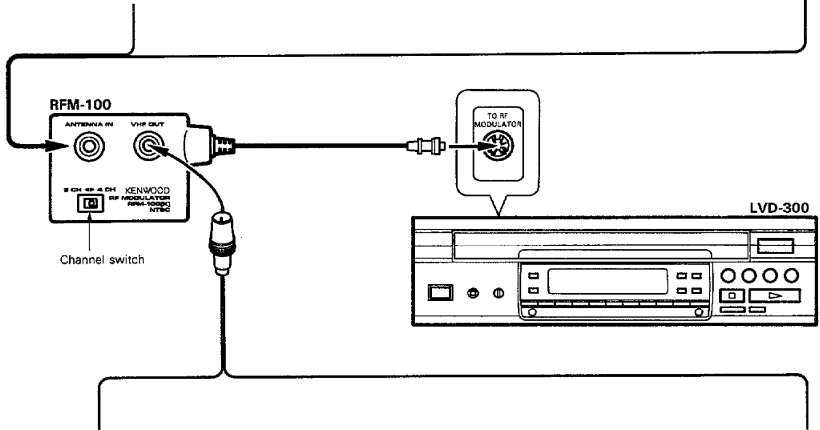
TV antenna connection		The connection method differs depending on your antenna wire type.	
TV antenna (VHF)	Coaxial cable	Coaxial cable	Feeder wire
	With F connector 	Without F connector Attach an antenna adaptor. 	Attach an antenna adaptor. 

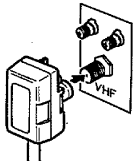
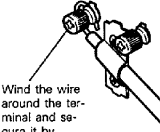
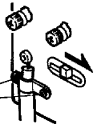

TV connection		Make this connection according to your TV's antenna terminals.	
F connector type	F connector type	Screw connector type	Screw connector type
	Attach the antenna adaptor. 	For a 75 Ω terminal  <p>Wind the wire around the terminal and secure it by tightening the screw.</p>	For a 300 Ω/75 Ω terminal Set the 75 Ω/300 Ω switch to the 75 Ω position.  <p>Tighten the screws.</p>

Notes:

1. Connect all cords firmly. If connections are loose there could be loss of sound or noise produced.
2. When plugging and unplugging connection cords after connections are complete, be sure to first remove the power cord from the AC outlet. Plugging/unplugging connection cords without removal of the power cord can cause malfunctions or damages to the unit.

■ Operation when using an RF modulator connection

- 1 Set the channel switch to the desired channel.

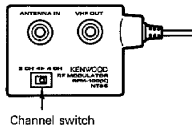

- Channel 3 or channel 4 can be selected. Set to the channel number corresponding to the vacant channel in your area.

- 2 Press the TV/DISC key on the remote control unit.



- When the power to this unit is turned on, the signal from this unit (disc) is supplied to the TV's antenna terminal.
- Each time you press the remote control unit's TV/DISC key, the signal supplied to the TV's antenna terminal is switched between the signal from the antenna and the signal from this unit.
- When the power to this unit is turned OFF, the signal from the antenna is supplied to the TV's antenna terminal.

■ Coaxial cable connection (Except for some areas)

- 1 Arrange the coaxial cable as illustrated.

When using a RG-6 (5C-2V) cable, remove the outer insulation and expose the core wire.

When using a RG-59 (3C-2V) cable, remove the outer insulation and fold the mesh wire back over the insulation.

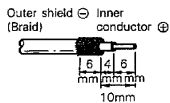
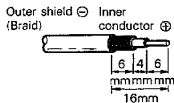

- 2 Open the 75 Ω/300 Ω antenna adaptor.

Press the claws in the direction of the arrows with the fingers to release the lock and pull out the cover.

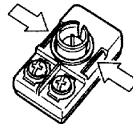

- 3 Detach the ring from the antenna adaptor. Then put the ring on the pole in the cover.

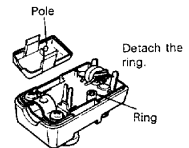

- 4 Remove the band and insert the inner conductor to the slit.

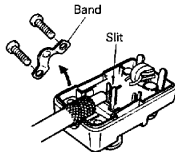

- 5 Fasten the band with screws, using a screwdriver.

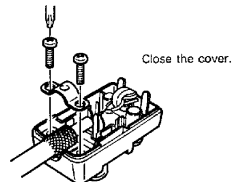

Optical fiber cable connection

Before connecting the optical fiber cable, remove the protection cap from the terminal.

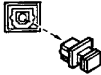

Insert the optical fiber cable connector straight-forward into the terminal until it clicks.

- Be sure the protection cap is attached to the optical terminal when the terminal is not being used.
- Be careful not to bend, coil, or bundle the optical fiber cable.

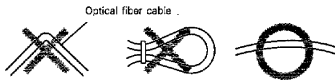

- Optical fiber cables available on the market may not always be able to be used with this player. If your cord cannot be used with this unit, consult the store from which you purchased the cord or your nearest dealer.

S-VIDEO terminal:

The S-VIDEO signal system separates the normal video signal (composite signal) into a signal which conveys brightness (Y signal) and a signal which conveys color (C signal), and transmits these signals independently. Use this terminal for superior picture quality.

Video terminal configurations:

The configurations of the S-VIDEO and VIDEO (composite) terminals are as shown below.

S-VIDEO terminal



VIDEO terminal



■ Using the stereo headphones

- 1 Insert the headphone plug into the PHONES jack.



- 2 Adjust the volume level.

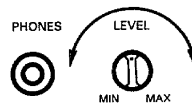

■ System Control cord connection

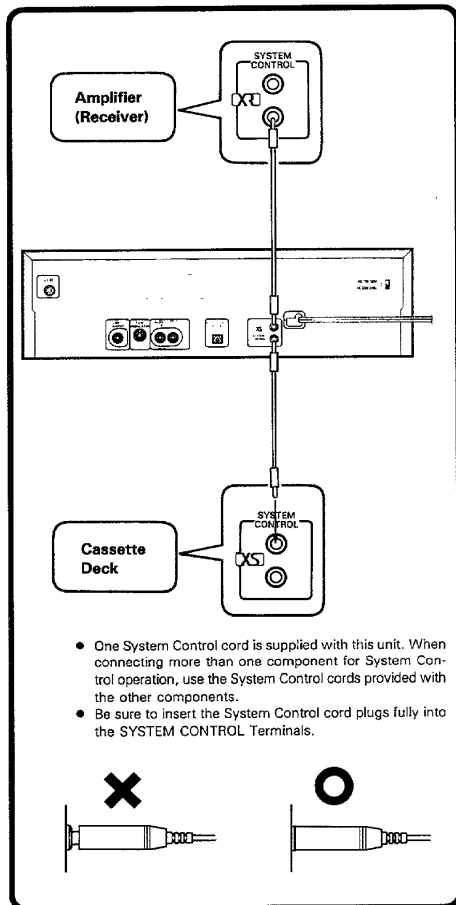

SYSTEM CONTROL terminal

By connecting this terminal to a KENWOOD amplifier or cassette deck equipped with a System Control terminal, you can gain access to a variety of system operations. To avoid possible malfunction, do not connect this terminal to any component except for those specified by KENWOOD.

System operation

1. Connection with an amplifier

System Control terminals found on KENWOOD amplifiers are marked with "XS" or "XS". Using a System Control cord to connect this unit to a KENWOOD amplifier enables you to carry out the following operations.

When connected to an "XS" terminal:

System remote control operations are possible using the amplifier's remote control unit.

When connected to an "XS" terminal:

System remote control operations and "Easy Operation" are possible.

For details, refer the amplifier's instruction manual.

2. Connection with a cassette deck

Using a System Control cord to connect this unit to a cassette deck bearing the "XS" mark enables you to carry out "CCRS recording."

CCRS

The CCRS function is used when recording from a compact disc to a tape in a cassette deck, and operates to adjust the cassette deck's recording level to the optimum setting according to the playing level of the compact disc. For details on the CCRS function, refer to the instruction manual provided with your cassette deck.

Notes:

1. When setting up your system for System Control operation, connect the AUDIO OUTPUT jacks or VIDEO OUTPUT jack of this unit to your amplifier's input jack(s) using an audio cord (video cord).
2. When using an amplifier that does not have a "CD/VDP (LD)" input selector position (an amplifier with no video input jack), do not connect the amplifier to this unit using a System Control cord.

Controls and indicators

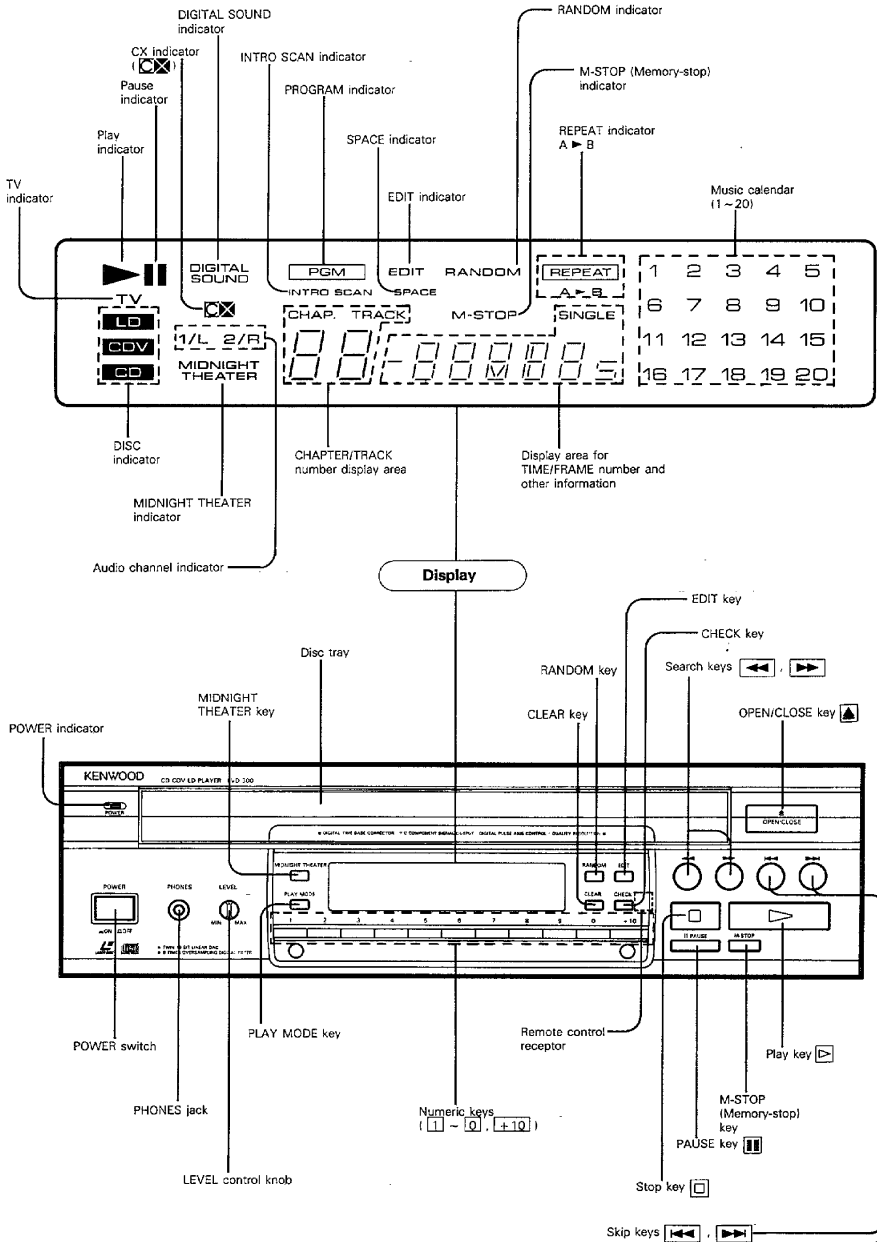

Remote control operation

All of the functions of the main unit can be operated using the remote control unit (except for the POWER switch). Operations of keys marked with "*" can also be carried out on the main unit.

Loading the batteries

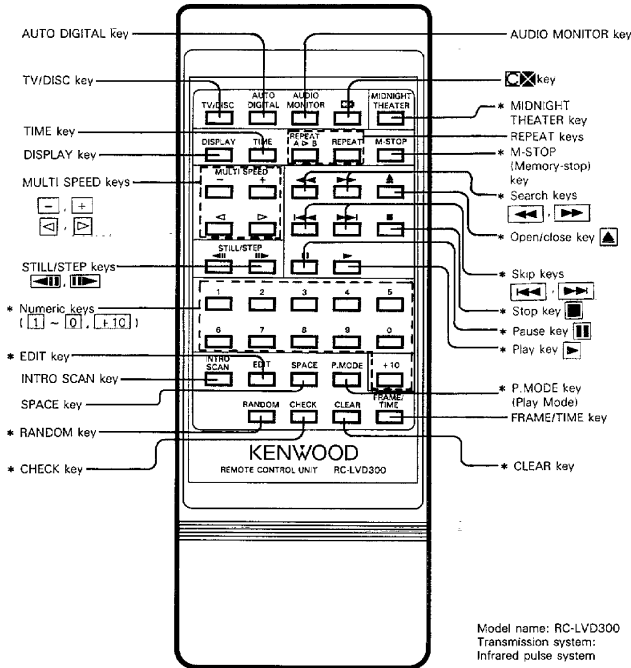

Model name: RC-LVD300
Transmission system:
Infrared pulse system

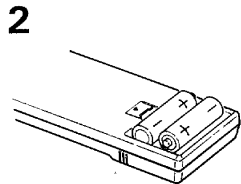
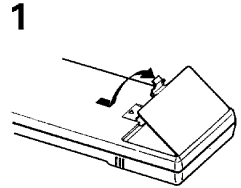

Insert two AA-size dry batteries (R6) in accordance with the indicated polarity marks.

3 Close the cover.

Operation

The coverage angle and distance varies depending on the temperature and humidity. Refer to the following illustration for the approximate operation range.

- When pressing the remote control operation keys, press them securely, leaving an interval of more than 1 second between them.

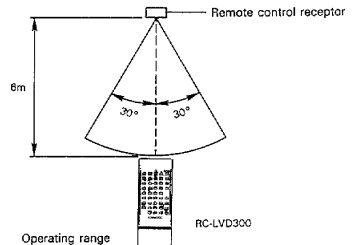

Notes:

- The supplied batteries are intended for use in checking the operation of the unit and may have a short life.
- When operating distance range of the remote control unit becomes noticeably shorter, replace all two of the batteries with new ones.
- Malfunction may occur in case direct sunlight or the light of a high-frequency lighting fluorescent lamp enters the remote control light receptor. In such a case, change the installation position of the unit so that the malfunction does not occur.

Normal playback operation (CD, CDV, LD)

■ Playing a disc

- 1** Turn on the power to this unit and related components.

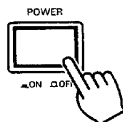

- Playback begins automatically if a disc is present in the player when the power is turned on.

- 2** Open the disc tray.

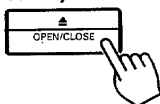

- 3** Set a disc on the disc tray.

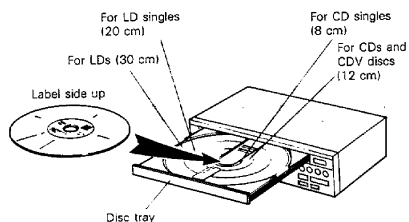

- 4** Play the disc.

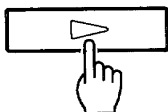

- The player identifies which type of disc is loaded and "PLAY" blinks on the display. Playback begins when "PLAY" stops blinking.
- Pressing the unit's OPEN/CLOSE button will close the disc tray but playback will not begin. To play the disc, press the play key.

Display during disc play

- ① When playing a CAV disc If the disc has a TOC, the recorded chapter number are displayed.

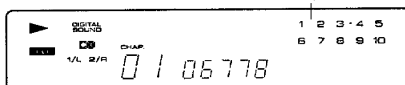

- ② When playing a CLV disc If the disc has a TOC, the recorded chapter number are displayed.

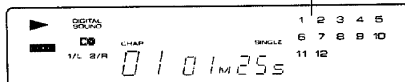

- ③ When playing a CD

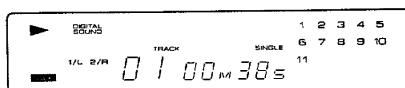

TV screen display during disc play

09 01:05 SINGLE



Notes:

1. Do not place any object on the disc tray other than a disc.
2. A disc may become scratched if placed on the tray at a slant.
3. Only place one disc at a time on the disc tray. Placing two or more discs on the tray may damage the unit.

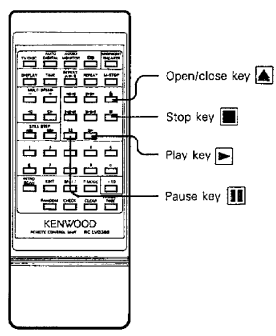
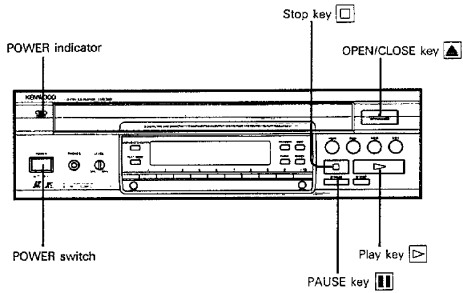

■ Pausing playback

Chapter (track) numbers which have already been played are extinguished.

- Audio and video are suppressed and the pause indicator (II) lights.
- Pressing the play key once more starts playback from the paused position.

■ Stopping playback

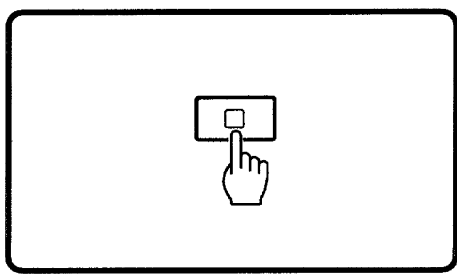

■ Removing the disc

- The disc tray ejects, allowing you to remove the disc.
- Press the OPEN/CLOSE key again to close the disc tray.

Note:

To protect your discs, never turn the POWER switch OFF during playback. Always press the stop key and then the OPEN/CLOSE key to remove the disc before turning the power off.

Searching for a desired scene (tune) (CD, CDV, LD)

Chapter number (LD)

Like a book, LDs are divided into "chapters," each of which is assigned a chapter number. Chapter numbers are used on the jacket cover to designate the disc contents.

- Some discs are not recorded with chapter numbers.

Track number (CD, CDV)

Track numbers are used to designate the various sections of a disc. CDV discs are recorded with track numbers which continue in sequence from the audio part to the video part.

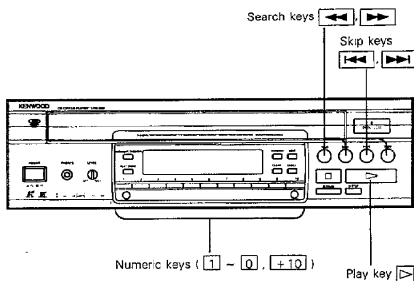

■ Locating a desired scene (tune) by chapter (track)

(Chapter Search) (Track Search)

Searching using the numeric keys

Specify the chapter number (track number) using numeric keys.

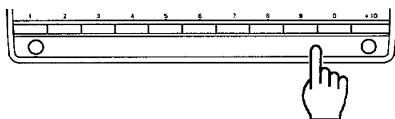

Input example:

14 is input by pressing +10 once and then pressing 4.
20 is input by pressing +10 twice and then pressing 0.

- When searching is finished, the original operation mode resumes.

Searching using the skip keys

Press the skip key corresponding to the direction in which you wish to search.



- Each time the [▶] key is pressed, the play position advances to the next chapter (track).
- If [◀] is pressed once during playback, the play position returns to the beginning of the current chapter (track). If pressed again, the play position returns to the preceding chapter (track).
- When searching is finished, the original operation mode resumes.

■ Locating a desired scene (tune) by fast-forwarding/fast-reversing

(Manual Search)

- 1 Press the key corresponding to the direction in which you wish to search.

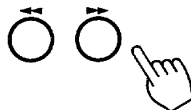

- If pressed for more than 2 seconds, fast-forward/fast-reverse will continue even if you remove your finger from the key.
- No sound is heard during fast-forwarding or fast-reversing. (LD, CDV video part)
- When the end of the video part is reached during fast-forwarding, the play position moves to the audio part and normal playback begins. (CDV)
- Fast-reversing from the audio part to the video part is not possible. (CDV)

- 2 Start normal playback.

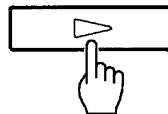

Notes:

1. Chapter Search and Chapter Skip operations are not possible with discs which do not have chapters.
2. If you designate a chapter number which is not on the disc when using a disc that does not have a TOC, operation will stop after the player determines that the specified chapter does not exist.
3. Noise may appear on the screen during fast-forwarding or fast-reversing.

Frame number (LD)

"Frame" is the name given to each image recorded on a standard play (CAV) disc, and is equivalent to a "page" in a book. By designating one of the frame numbers recorded on the disc, you can begin playback from any desired scene.

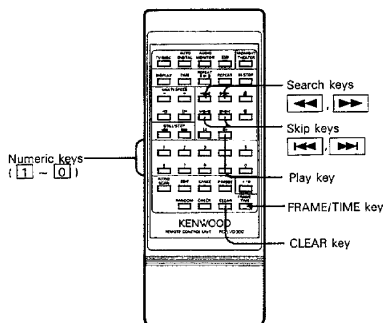

■ Locating a desired scene by frame number (LD-CAV only)

Example: Starting playback from frame number "12345".

1 Press the FRAME/TIME key.

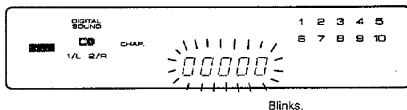

2 Within 5 seconds, designate the frame number (5 digits) using the numeric keys.

Press **1** **2** **3** **4** **5** in sequence.

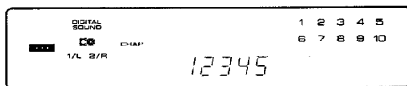
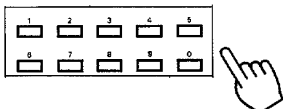

- If you mistakenly enter the wrong frame number, press the CLEAR key once and then re-enter the number.
- If the CLEAR key is pressed twice, Frame Search is not carried out and the unit enters the original mode.

3 Start playback.

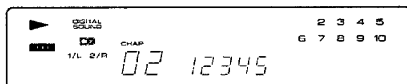
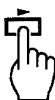

- After a short delay, playback begins from the designated frame.
- Frame Search is canceled if you do not press the play key within 5 seconds after entering the frame number.
- If Frame Search is carried out while a still frame or paused image is on the screen, the player locates the designated frame number and then enters the original mode (i.e., still frame or pause mode). To start normal playback, press the play key again.

Notes:

1. If you designate a frame number which is not recorded on the disc, operation will stop after the player determines that the specified frame does not exist.
2. Frame Search cannot be carried out during A>B repeat play.

Time number

Time numbers are recorded on extended play (CLV) discs and indicate the elapsed play time from the beginning of the disc. Time numbers are recorded in second units or minute units, depending on the disc.

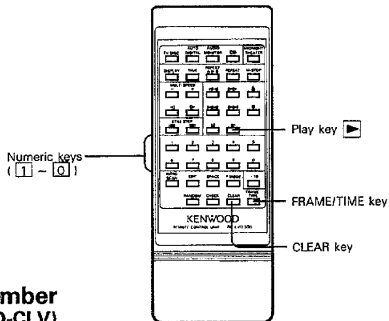

■ Locating a desired scene (tune) by time number (CD, CDV, and LD-CLV)

Example: Starting playback from an elapsed time of 12 min. 34 seconds.

1 Press the FRAME/TIME key.



If the disc has a TOC, the recorded chapter numbers are displayed.

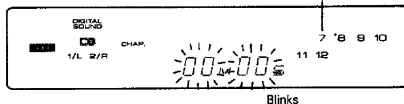

- With CDV discs, this operation is possible only while the disc is playing. Search is carried out only for the audio part when the audio part is playing, and only for the video part when the video part is playing.

2 Within 5 seconds, designate the time (4 digits) using the numeric keys.

Press **1** **2** **3** **4** in sequence.

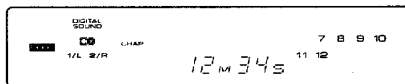
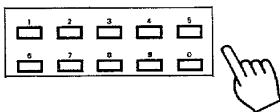

- If the time numbers on the disc are not recorded in second units, designate the time in minute units (2 digits).
- If you mistakenly enter the wrong time number, press the CLEAR key once and then re-enter the number.
- If the CLEAR key is pressed twice, Time Search is not carried out and the unit enters the original mode.

3 Start playback.

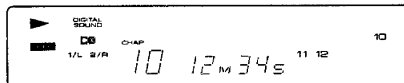

- After a short delay, playback begins from the designated time number (elapsed time).
- If Time Search is carried out while paused image is on the screen, the player locates the designated time number and then enters the original mode (i.e., pause mode). To start normal playback, press the play key again.
- Time Search is carried out for the TOTAL elapsed time.

Notes:

1. If you designate a time number which is not recorded on the disc, in the case of an LD operation will stop after the player determines that the specified time number does not exist; in the case of a CD or CDV disc the last track will be played and then operation will stop.
2. Time Search cannot be carried out during A>B repeat play.

Audio switching

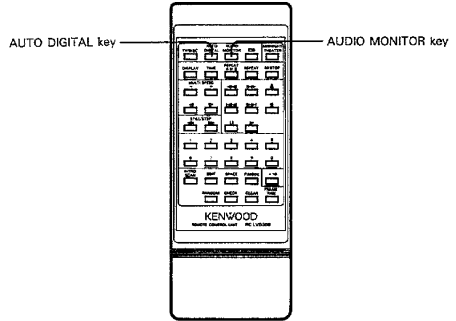

■ Selecting the desired audio

Press the remote control unit's **AUDIO MONITOR** key.

Each time the **AUDIO MONITOR** key is pressed, the audio changes according to the following sequence:

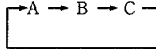

- When the power is turned on, the audio is set for stereo ("A" in the table). Press the **AUDIO MONITOR** key when you wish to listen to sound from only the left or right channel, or when you wish to select the English channel or other language channel from a bilingual source.

	Audio heard from speaker(s)		Indication	
	Stereo disc	Bilingual	Display	TV screen
A	Stereo	Audio 1 (left) Audio 2 (right)	1/L 2/R	STEREO
B	Left channel	Audio 1 (left)	1/L	1/L
C	Right channel	Audio 2 (right)	2/R	2/R

■ Playing digital audio discs

There are two types of audio recording used with LDs: digital recording and analog recording. Digital audio LDs also contain analog recorded audio, allowing you to select either type of audio.

Discs which bear one of the logos shown at the right give output priority to digital audio. To listen to analog audio, press the **AUTO DIGITAL** key on the remote control unit.

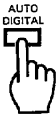

**digital
SOUND**

**digital
AUDIO**

**digital
SOUND MULTI AUDIO**

Digital audio disc logos

Multi Audio disc logo

- Each press of the key switches between digital audio and analog audio.

- You can get full enjoyment from Multi Audio discs by making use of both the **AUDIO MONITOR** key and the **AUTO DIGITAL** key.

Special video playback functions (LD-CAV)

Special video playback functions are not possible with CLV (extended play) discs.

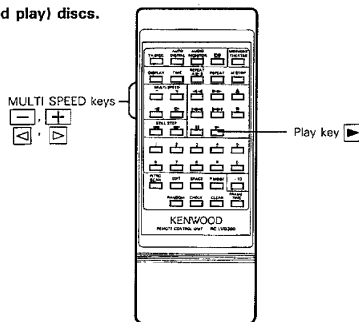

■ Changing the playback speed

- 1** Press the remote control unit's **MULTI SPEED** (\triangleright , \triangleleft) key.

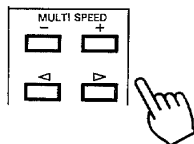

- Pressing the \triangleright side selects forward motion.
- Pressing the \triangleleft side selects reverse motion.

- 2** Select the speed using the \oplus and \ominus keys.

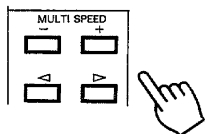

- Eight speeds can be selected, with each press changing the speed in the following order.

- $\times 3$ Three times the normal speed
- $\times 2$ Two times the normal speed
- $\times 1$ Normal speed
- $\times 1/2$ Half the normal speed
- $\times 1/4$ One-fourth the normal speed Initial setting
- $\times 1/8$ One-eighth the normal speed
- $\times 1/16$ One-sixteenth the normal speed
- $\times 1/30$ One-thirtieth the normal speed

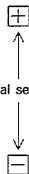

- No sound is output when using the MULTI SPEED function.

To resume normal playback

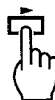

TV screen display:

Chapter number and frame number display

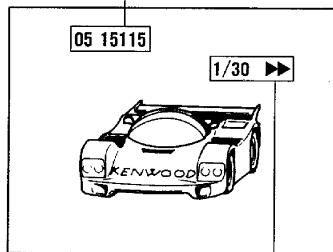

Speed and direction display ($\times 3 - 1/30$)

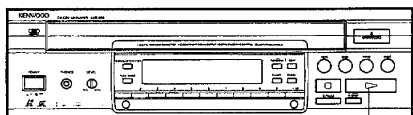

Play key 

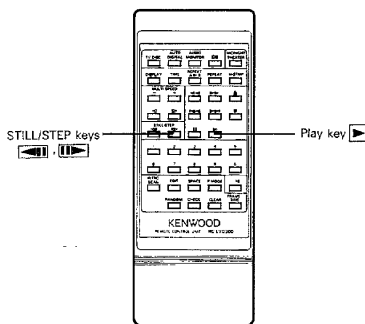

STILL/STEP keys 



Play key 

■ Stopping and viewing single frames

Still frame, frame advance, and frame reverse are possible.

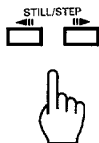
Press the remote control unit's STILL/STEP key.



- The first press stops the image and displays a still frame.
- Each press of the  side advances the image by one frame.
- Each press of the  side reverses the image by one frame.
- No sound is output when using the still frame, frame advance, or frame reverse function.

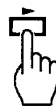

To resume normal playback

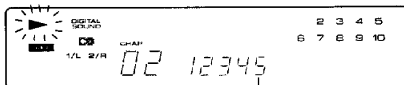

Display indications

Blinks.



The frame number is increased or decreased by one frame each time the STILL/STEP key ( , ) is pressed.

Note:

The image may become disrupted during still frame, frame advance, or frame reverse mode. This is neither a malfunction of the unit nor a disc defect.

Automatic Picture Stop Function

When playing a disc recorded with special signals called "picture stop codes", the unit will automatically enter still frame mode when it plays a frame that contains such a code. Following the screen display, enjoy the image using keys such as the STILL/STEP key.

Program Play (CD, CDV, LD)

Up to 20 chapters (tracks) can be programmed and played in any desired order.

- Programming is not possible with discs that do not have chapter numbers.

■ Playing desired chapters (tracks) in the desired order

Program Mode

1 Set the player to Program mode.

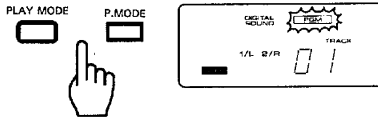

- Program mode cannot be set if the unit is in A>B Repeat mode. In this case, press the REPEAT A>B key to cancel A>B Repeat mode.

2 Use the numeric keys to designate the chapter (track) numbers you wish to program.

Example: Selecting chapter numbers 3, 9, and 15. Press the numeric keys in the following order:

3 **9** **+10** **5** .

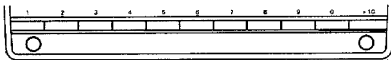

- If you make a mistake during entry, press the CLEAR key and then re-enter the number(s).

3 Start program play.

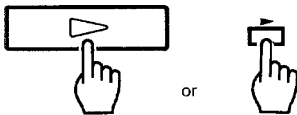

- The designated chapters (tracks) are played in the programmed order.
- To play the next or previous chapter (track) in the program, press the **▶▶** or **◀◀** skip key.

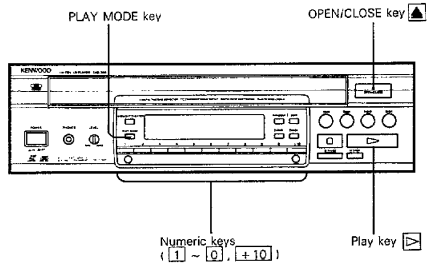

■ Repeatedly playing a program

Press the REPEAT key on the remote control unit.

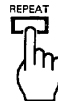

- **REPEAT** appears on the display and the program is played repeatedly.
- To cancel repeat play, press the REPEAT key again.

To create blank spaces between tunes

After setting the player to Program mode, press the remote control unit's SPACE key.



- A blank space of approximately 4 seconds is created between tunes. This function is useful when recording cassette tapes for use with the cassette deck's tune skip function.
- The total time display changes to include the time required for the spaces.
- To cancel, press the SPACE key again.

■ Checking a program

Press the CHECK key.



- Each time the key is pressed, the next chapter (track) number is displayed in the programmed order.

■ Changing a programmed chapter (track)

- 1 Press the CHECK key to select the programmed chapter (track) number you wish to change.

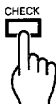

- The next chapter (track) number in the program is displayed each time you press the CHECK key.

- 2 Enter the number of the desired chapter (track).

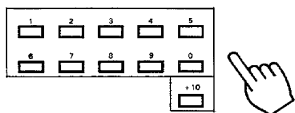

- A program cannot be changed while it is being played.

■ Adding to a program

Enter the chapter (track) number(s) you wish to add.

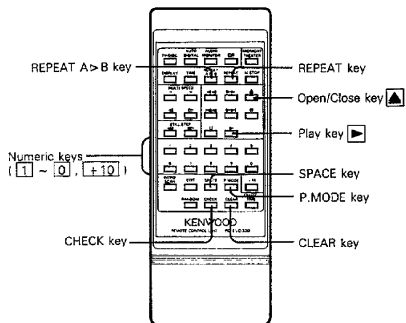
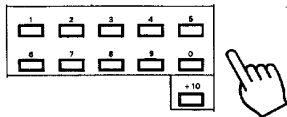

■ Deleting programmed chapters (tracks)

Programmed chapter (track) numbers are deleted one-by-one in reverse order.

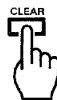

- Each time the CLEAR key is pressed, the last chapter (track) number in the program is deleted.
- During program play, chapter (track) numbers which have already been played (including the current chapter/track) cannot be deleted.

Deleting the entire program

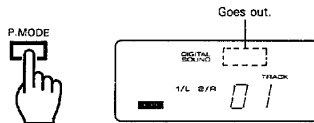

- Pressing the OPEN/CLOSE key also deletes the program in addition to opening the disc tray.

Note:

During program play, if you have programmed a chapter which is not on the disc when using a disc which does not have a TOC, the unit will play the next chapter in the program after verifying that the current chapter does not exist.

When recording tunes from a CD or CDV disc to cassette tape, this function is used to edit the tunes so that they fit within the time limits of side A and side B so the last tune on each side does not get cut off in the middle.

■ Editing

1 With the player in Stop mode, press the EDIT key.

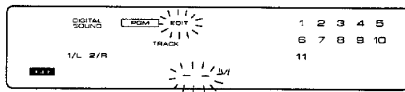

- If you wish to make 4-second, blank spaces between tunes, press the SPACE key on the remote control unit after pressing the EDIT key.

2 Use the numeric keys to input the total recording length of the tape (both sides) in minute units.

Example: To edit for a 46-minute tape, press **[+10]** four times and then press **[6]**.

To correct a mistaken entry, press the CLEAR key and then re-enter the recording time.

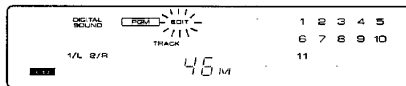
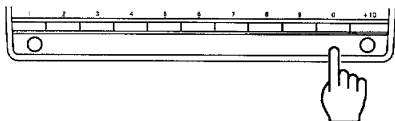

- Recording times of 100 minutes or more cannot be input.
 - The player edits the tunes as described below.
- ① The input recording time is divided in half (resulting in 23 minutes in the example), and then the player automatically selects the track numbers of tunes to fill the A file (side A of the tape).
 - ② After a few seconds, the remaining time left on side A appears on the display, and then the player edits the B file (side B of the tape) in the same manner.

Editing sequence	TV screen display example	Player display example (when using a CD)
Editing begins A edit	EDIT-A	
A edit completion	EDIT-A REMAIN = 01:03	
B edit	EDIT-B	
B edit completion	EDIT-B REMAIN = 01:45	
Edit completion	01-43:12 TOTAL STOP CD	

■ Checking an edited program

Press the CHECK key.



- Each time the CHECK key is pressed, the next track number in the edited program sequence is displayed, starting at the beginning of the A file and continuing to the B file.

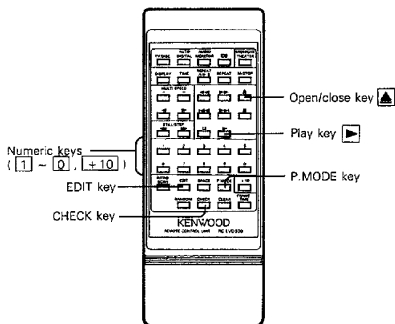

■ Playing an edited program

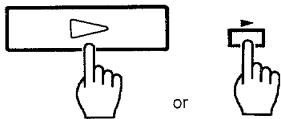

- Playback begins of the tunes in the A file. When the last tune in the A file has finished playing, the unit enters pause mode. Pressing the play key again starts playback of the tunes in the B file.

■ Deleting the entire edited program

Press the P.MODE key.

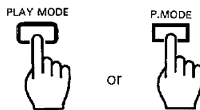

Press the OPEN/CLOSE key.

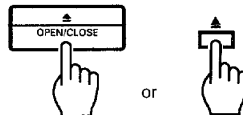

Using the Program and Edit functions together

If you program a number of tunes before carrying out the editing operation, the unit will give priority to the programmed tunes when it carries out the editing process. If there is surplus recording time still left in a file after all of the programmed tunes have been edited, the unit will automatically carry out additional editing to fill the remaining time with non-programmed tunes.

Notes:

- If you enter a recording time which differs from the length of the tape you are using, editing will be carried out normally but excessive blank space may be left on the tape or the last tune on side A or B may get cut off in the middle.
- The Edit function can edit a maximum of 20 tunes.
- If a tune with a track number of 36 or greater is included in a program, the Edit function will not operate.
- Editing may not be carried out properly if you use a disc which contains only one tune or a disc such as a classical music CD which contains one track number that has a long playback time.

Repeat play

■ Repeatedly playing one side of a disc

- 1** Make sure [PGM] is extinguished on the display.

Extinguished.

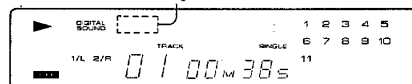

- If [PGM] is lit, press the P.MODE key.

- 2** Press the remote control unit's REPEAT key once.

REPEAT

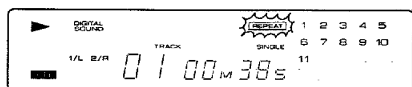

- This is not possible during A>B repeat play.
- To cancel, press the REPEAT key again.

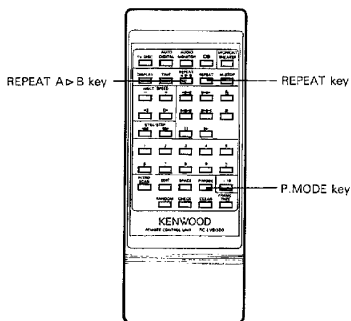

■ Repeatedly playing a desired section (A>B Repeat)

- 1** While the disc is playing, press the remote control unit's REPEAT A>B key at the start of the section you wish to repeat.

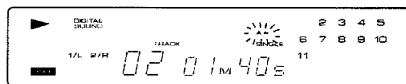

- Check to make sure that [PGM] and [REPEAT] are extinguished in the display.

- 2** Press the REPEAT A>B key again at the end of the section you wish to repeat.

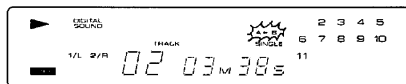

- The designated section is played repeatedly.
- To cancel A>B repeat play, press the REPEAT A>B key again. (Normal playback resumes.)
- When using a disc which has time numbers recorded in minute units, the boundaries of the designated section may be slightly shifted during playback.

Time number (minute) display

	01.	02.	03.	04.
Example 1	A --- B			
Example 2		A --- B		
Example 3	A ---		--- B	

A --- B indicates the designated section.

← → indicates the actual repeated section.

Random play

The Random Play function plays all of the tunes on a disc in random order by randomly selecting the next tune at the end of each tune. (CDs, CDV discs, and LDs that have a TOC.)

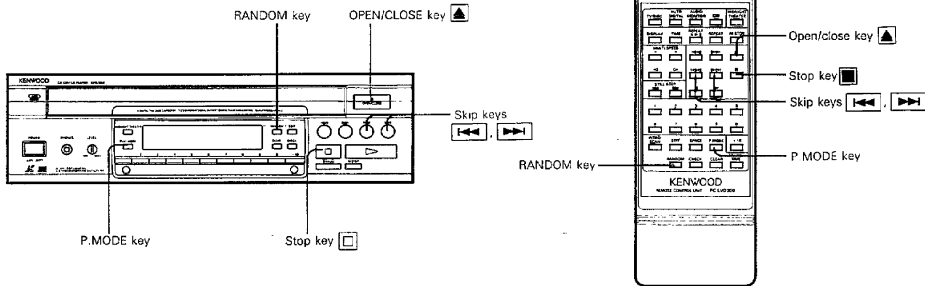

■ Random play

- 1 Make sure **PGM** is extinguished on the display.

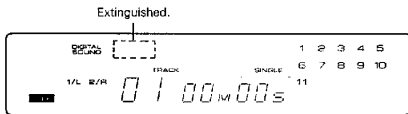

- If **PGM** is lit, press the P.MODE key.

- 2 Press the **RANDOM** key.



- The "PLAY" indicator blinks while the first tune is being selected. When the tune is selected, the track number for that tune only appears in the display and playback begins.
- When one tune finishes playing, the player randomly selects another tune and begins playing that tune.
- If Repeat Play has been set (the **REPEAT** indicator is lit), pressing the **RANDOM** key causes the **REPEAT** indicator to go out and priority is given to the Random Play function.

To select another tune during Random Play

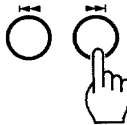

- If you press the skip key, the player returns to the beginning of the current tune and the same tune is played again.

To resume normal playback

Press the **RANDOM** key again.



- Normal playback resumes from the current tune.
- If you press the stop key or OPEN/CLOSE key, Random Play will be canceled and playback will stop.

Switching the time display

Time display switching

Each time the **TIME** key is pressed, the contents of the time display change according to the sequences listed below according to disc type and play mode.



Explanations for items marked with an asterisk (*) appear after the table.

Disc type	TOC existence	Mode	Display contents	
LD	CLV	With TOC	*Manual mode	① Total elapsed time of the disc → ② Total remaining time of the disc ④ Remaining time of the current chapter ← ③ Elapsed time of the current chapter
			Program mode	① *Absolute time → ② Elapsed time of the current chapter ③ Remaining time of the current chapter ←
		Without TOC	*Manual mode	Total elapsed time of the disc
			Program mode	*Absolute time
	CAV	With TOC	*Manual mode	① Frame number → ② Elapsed time of the current chapter → ③ Remaining time of the current chapter ⑥ Total remaining time of the disc ← ⑤ Total elapsed time of the disc
			Program mode	① Frame number → ② Elapsed time of the current chapter ④ *Absolute time ← ③ Remaining time of the current chapter
		Without TOC	*Manual mode	① Frame number → ② Total elapsed time of the disc
			Program mode	① Frame number → ② *Absolute time
CD, CDV		*Manual mode	① Elapsed time of the current track → ② Remaining time of the current track → ③ Total elapsed time of the disc ④ Total remaining time of the disc ←	
		Program mode	① Total remaining time of the program → ② Elapsed time of the current track ④ Total elapsed time of the program ← ③ Remaining time of the current track	

*Absolute time: This is the time recorded on the disc and indicates the elapsed time from the beginning of the disc.

*Manual mode: Modes other than Program mode.

Display examples: For a CLV disc with a TOC

① Total elapsed time of the disc

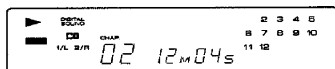

② Total remaining time of the disc

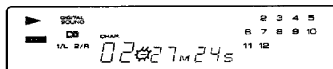

③ Elapsed time of the current chapter

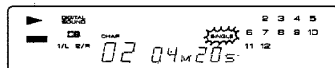

④ Remaining time of the current chapter

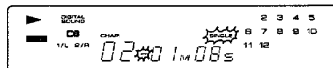

■ Timer playback

To carry out timer playback, connect an audio timer between this unit and the AC power supply, load a disc, set the timer to the desired time, and set this unit's POWER switch to ON.

- When the set time is reached, power is supplied to the unit and playback automatically begins.

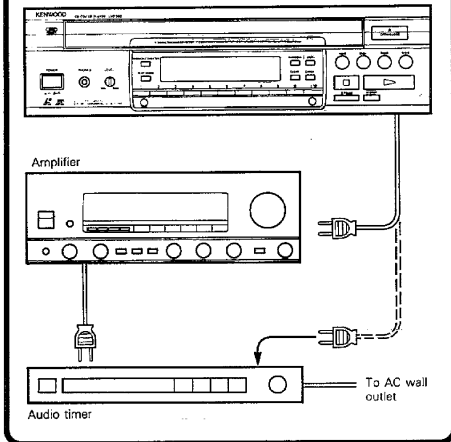

Notes:

1. Be sure to read the instruction manual supplied with the audio timer.
2. When carrying out timer playback, be careful that the volume level on the amplifier is not set too loud.
3. When using the timer to operate a component other than this unit, be sure to remove the disc from this unit.

INTRO SCAN function

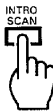

When you press the INTRO SCAN key, the unit plays the first seconds of each chapter (or track).

- In program mode, the unit plays the first part of each chapter (or track) in the programmed order.
- If you press the INTRO SCAN key again, normal playback starts from the current position.
- When playing a disc that has no chapters, INTRO SCAN is not carried out.

DISPLAY key

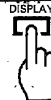

Each time the DISPLAY key is pressed, the display changes according to the following sequence.

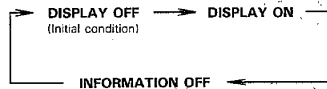

① DISPLAY ON

The various character displays appear on the screen regardless of whether or not a video signal is present.

- The screen appears blue if there is no video signal.

② DISPLAY OFF

No character displays appear on the screen when a video signal is present (when a video image is on the screen).

- If there is no video signal, the screen turns blue and character displays appear on the screen.

③ INFORMATION OFF

No character displays appear.

- The screen appears blue if there is no video signal.
- The display on the unit only shows the chapter (track) number and the time or frame number.

MEMORY STOP function

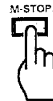

If you press the M-STOP key during playback, the player memorizes the current position and enters stop mode. If you then press the play key, playback will start again at the memorized position.

- To cancel the Memory Stop function, press the M-STOP key again.

MIDNIGHT THEATER function







When you press the MIDNIGHT THEATER key, the volume level of the movie sound effects is lowered to the same level as the dialogue, making it easier to hear what the people in the movie are saying. This is especially convenient when watching movies at low volume levels.

- To cancel, press the MIDNIGHT THEATER key again.

In case of difficulty

What appears to be a malfunction may not always be serious. If your unit should not perform as expected, consult the table below to see if the problem can be corrected before seeking help from your dealer or service representative.

Symptom	Cause	Remedy
The power does not come on when the power switch is pressed.	<ul style="list-style-type: none"> The power cord is not plugged in completely. Power to the amplifier is turned off. 	<ul style="list-style-type: none"> Securely plug the power cord into the outlet. Turn on the power to the amplifier.
Playback does not start when the play  key is pressed.	<ul style="list-style-type: none"> The power is not turned on. There is no disc in the player. There are no signals recorded on the side of the disc being played. 	<ul style="list-style-type: none"> Press the player's power switch. Load a disc and press the play  key. Turn the disc over and properly place it on the disc tray.
The play indicator  is lit but no image/sound is seen/heard.	<ul style="list-style-type: none"> The TV is not turned on. The connection cords are not properly connected. The TV's input switch is not set properly. 	<ul style="list-style-type: none"> Turn on the TV. Properly reconnect the connection cords. Set the switch to TV or VIDEO. (Set to TV when using an RF modulator.)
Television programs do not come in.	<ul style="list-style-type: none"> The TV antenna is not connected properly. The output of the RF modulator is switched to VDP (DISC) side. The TV's input switch is set to VIDEO. 	<ul style="list-style-type: none"> Properly connect the antenna. Press the remote control unit's TV/DISC key. Set the switch to TV.
Still frame, frame advance, or Multi Speed playback cannot be carried out.	<ul style="list-style-type: none"> The disc is an extended play (CLV) disc. 	<ul style="list-style-type: none"> Still frame, frame advance, and multi speed playback functions are not possible with extended play (CLV) discs.
During LD playback, the picture becomes disrupted when the image is fast-forwarded or fast-reversed.	<ul style="list-style-type: none"> The picture will be slightly disrupted during fast-forward and fast-reverse operations. 	<ul style="list-style-type: none"> This is not a malfunction.
No sound is heard.	<ul style="list-style-type: none"> The audio output cord is not properly connected. The volume control of the TV or amplifier is not adjusted properly. The player is in a special playback mode. 	<ul style="list-style-type: none"> Properly connect the audio cord. Set the sound volume to an appropriate level. Press the play  key to resume normal playback mode.
The picture does not look good, picture/sound quality is poor.	<ul style="list-style-type: none"> The video cord is not properly connected. A nearby device is generating noise. The disc is dirty. The disc is scratched or flawed. There is condensation on the optical lens. 	<ul style="list-style-type: none"> Properly connect the cord. Separate this unit as far as possible from the device you think is generating the noise. Refer to the "Disc Handling Precautions" section and wipe the dirt from the disc. Use a new disc. Refer to the "Beware of condensation" section and evaporate the condensation.
The player cannot be operated using the remote control unit.	<ul style="list-style-type: none"> The power to this unit is not turned on. The batteries are not properly inserted in the remote control unit. The batteries are dead. The remote control unit is operated too far from the player or at an improper angle. 	<ul style="list-style-type: none"> Turn on the power. Check the polarity of the batteries and reinsert the batteries correctly. Replace all two batteries with new ones. Use the remote control unit in the specified operating range.
It takes a while for the disc to start playing.	<ul style="list-style-type: none"> Time is required for the unit to detect the disc type and size and for the rotation of the motor to stabilize. This is not a malfunction. 	<ul style="list-style-type: none"> Approximately 10~20 seconds is required for a disc to start playing, although the time differs depending on the disc.
The disc tray automatically opens.	<ul style="list-style-type: none"> The disc is placed on the tray at slant. 	<ul style="list-style-type: none"> Properly place the disc on the tray.

Note:

- Since this unit incorporates a microprocessor, external noise or interference may cause the unit to operate abnormally. If this should ever occur, press the POWER switch OFF and then press it ON again after a period of several seconds.
- Do not use contact cleaner because it could cause a malfunction. Be specially careful against contact cleaners containing oil, for they may deform the plastic components.

For the U.S.A.**FCC WARNING:**

This equipment may generate or use radio frequency energy. Changes or modifications to this equipment may cause harmful interference unless the modifications are expressly approved in the instruction manual. The user could lose the authority to operate this equipment if an unauthorized change or modification is made.

NOTE:

This equipment has been tested and found to comply with the limits for a CLASS B digital device, pursuant to Part 15 of the FCC Rules. These limits are designed to provide reasonable protection against harmful interference in a residential installation. This equipment may cause harmful interference to radio communications, if it is not installed and used in accordance with the instructions. However, there is no guarantee that interference will not occur in a particular installation. If this equipment does cause harmful interference to radio or television reception, which can be determined by turning the equipment off and on, the user is encouraged to try to correct the interference by one or more of the following measures:

- Reorient or relocate the receiving antenna.
- Increase the separation between the equipment and receiver.
- Connect the equipment into an outlet on a circuit different from that to which the receiver is connected.
- Consult the dealer or an experienced radio/TV technician for help.

For CANADA**DOC REGULATION**

"This digital apparatus does not exceed the CLASS B limits for radio noise emissions from digital apparatus as set out in the radio interference regulations of the Canadian department of communications."

Specifications

[Type]

Video disc format..... LaserVision format
Signal read system..... Semiconductor laser
Video output format..... NTSC
Video output lines..... 2 lines (S-VIDEO terminal,
RCA pin jack)
Audio output lines..... 2 lines (optical terminal,
RCA pin jack)

[Characteristics]

Video output level..... 1 Vp-p (75 Ω load, sync. negative)
S-VIDEO output level..... Y output : 1 Vp-p (75 Ω load,
sync. negative)
C output : 0.286 Vp-p
(75 Ω load)

Horizontal resolution..... 425 lines
Video signal to noise ratio..... More than 49 dB

Digital audio section

Frequency response..... 4 Hz ~ 20 kHz
Signal to noise ratio..... More than 105 dB
Dynamic range..... More than 98 dB
Total harmonic distortion..... Less than 0.007% (1 kHz)
Wow and flutter..... Below measurable limit
($\pm 0.001\%$ W, PEAK)

Output level/Impedance..... 2 V/1 k Ω

Optical output (optical fiber output terminal)..... - 15 dBm ~ - 2 1dBm

RF modulator output channel..... VHF channel 3 or 4
(Except for some areas) (Supplied modulator:
RFM-100 switch type)

Allowable operating temperature range..... 5°C ~ 40°C

Allowable operating humidity range..... 5% ~ 90%
(condensation should not form)

[General]

Power consumption..... 40 W

Dimensions..... W: 440 mm (17-5/16")
H: 138 mm (5-7/16")
D: 374 mm (14-3/4")

Weight (Net)..... 10.0 kg (22.0 lb)

Note:

KENWOOD follows a policy of continuous advancements in development. For this reason specifications may be changed without notice.

KENWOOD